

Royal Vendors, Inc.

# Merlin IV

Service and Parts Manual



Manufactured by



**Royal Vendors, Inc.**

426 Industrial Boulevard  
Kearneysville WV 25430-2776 USA

Telephone +1 304 728 7056 • Fax +1 304 725 4016 • [technicalinquiry@royalvendors.com](mailto:technicalinquiry@royalvendors.com) • [parts@royalvendors.com](mailto:parts@royalvendors.com) • [www.royalvendors.com](http://www.royalvendors.com)



**Royal Vendors, Inc. • 426 Industrial Boulevard • Kearneysville WV 25430-2776 • USA**  
Customer Service: +1 304 728 7056 or Toll Free (*in North America only*) 1 800 931 9214 • Fax +1 304 725 4016

**E-mail:** [technicalinquiry@royalvendors.com](mailto:technicalinquiry@royalvendors.com)  
[parts@royalvendors.com](mailto:parts@royalvendors.com)

**Web page:** [www.royalvendors.com](http://www.royalvendors.com)

# Table of Contents

---

<b>Safety Segment.....</b>	<b>5</b>
<b>1. General Information.....</b>	<b>7</b>
Introduction to Merlin IV .....	7
Merlin IV Features.....	7
Vender Identification.....	8
Voltage Requirements.....	9
<b>2. Vender Component Explanation.....</b>	<b>10</b>
Vender Control Board (including pinouts) .....	10
Low Voltage Transformer .....	15
Delivery Chute Sensor.....	16
Refrigeration System .....	17
Ballast .....	19
Credit Peripherals .....	19
<b>3. Vender Programming.....</b>	<b>20</b>
The Necessity Of Correct Programming .....	20
Precautions To Take When Working With The Control Board.....	20
Introduction To Programming .....	20
Menu Levels .....	21
INTERNAL (Service) MENU .....	22
CASH (cash counter) Mode .....	22
SALE (sale counter) Mode .....	22
CARD (card counter) Mode.....	23
TOKEN (token counter) Mode.....	23
FREE (free vend accounting) Mode .....	23
ERROR (errors) Mode .....	24
TEST (column test vend) Mode .....	24
PRICE (selection price) Mode .....	24
SPACE (space to sales) Mode.....	25
DEPTH (set vending depth ) Mode .....	26
CONF (configurations) Mode.....	26
RETURN (return to sales) Mode.....	27
OPTIONAL MENU (If Con 2 is set “1”).....	27
EXACT (exact change mode) .....	27
COIN (coin payout) Mode.....	27
TUBE (coin tube fill) Mode .....	28
DISC (discounted sale counter) Mode.....	28
DIFF (discounted differential cash counter) Mode.....	28
DISC (discounted selection price) Mode.....	29
TIMER (set timer controlled selections) Mode.....	29
TIME (time and timer settings) Mode .....	30
REFR (refrigeration parameters) Mode.....	32
PASS (External Menu password setting) Mode.....	35
LANG (international language setting) Mode.....	35
RETURN (return to sales) Mode.....	35
External Menu (accessible while in the “greeting” mode).....	36
SALE (sale counter) Mode .....	36
RETURN (return to sales) Mode.....	36
ERROR (errors) Mode .....	36

# Table of Contents (continued)

---

<b>4. Vend Cycle</b> .....	<b>37</b>
Stand by Condition .....	37
Establishing Credit.....	37
Valid Selection .....	37
Vend Sequence.....	37
Product Delivery.....	37
Column Sequencing.....	37
Sold Out.....	37
Resetting Sold Out Selections .....	37
<b>5. Vender Maintenance</b> .....	<b>38</b>
General Maintenance.....	38
Using The Vender's Error Code System.....	39
Error Codes.....	39
Troubleshooting.....	40
Refrigeration Troubleshooting Flow Chart.....	46
<b>6. Training Guide</b> .....	<b>47</b>
<b>7. Exploded Views and Part Numbers</b> .....	<b>51</b>
Control Board and Wiring .....	52
Port Assembly.....	54
Inner Door Assembly.....	56
Main Door Hinge, Lifter, & T-handle Assemblies.....	58
Refrigeration System Assembly .....	60
Evaporator Fan Motor Assembly.....	62
Airflow Vend Mechanism Assembly (200422XX00001 and after).....	64
Vend Mechanism Assembly (before 200422XX00001).....	66
Miscellaneous Assemblies .....	68
Door Assembly, Front.....	70
Door Assembly, Rear.....	72
Select Panel Assembly, Rear.....	74
RVMC/RVCD Vandal Resistant Door (CDC) Front .....	76
RVMC/RVCD Vandal Resistant Door (CDC) Rear.....	78
RVMC/RVCD Center Door Changer Vault .....	80
Port Assembly, Dr Pepper Vision 4 .....	82
Door Assembly Front, Dr Pepper Vision 4 .....	84
Door Assembly Rear, Dr Pepper Vision 4 .....	86
Coin Insert Assembly Front, Dr Pepper Vision 4 .....	88
CI Rear and Button Panel Assembly, Dr Pepper Vision 4 .....	90
Changer Vault Assembly, Dr Pepper Vision 4 .....	92
Flat Horizontal Display, Door Front.....	94
Flat Horizontal Display, Door Rear.....	96
Flat Horizontal Display, Select Panel .....	98
<b>Programming Flowcharts</b> .....	<b>100</b>
<b>Schematics</b> .....	<b>102</b>

# Safety Segment

---

## ROYAL VENDORS' COMMITMENT TO SAFETY

Royal Vendors is committed to safety with all of our product designs. We are committed to notifying the user of a possible danger involving the improper handling or maintenance of our venders. The servicing of any electrical or mechanical device involves potential dangers, both to those servicing the equipment and to users of the equipment. These dangers can occur because of improper maintenance or usage. The purpose of this safety segment is to alert everyone servicing Royal equipment of potentially dangerous areas, and to provide basic safety guidelines for proper upkeep.

The service manual contains various warnings that should be carefully read to minimize the risk of personal injury. This manual also contains service information to ensure that proper methods are followed to avoid damaging the vender or making it unsafe. It is also important to understand these warnings provide general guidance only. Royal could not possibly know, evaluate, or advise of all of the conceivable ways in which service might be done. Consequently, Royal cannot predict all of the possible dangerous results. These outlined safety precautions are the basis for an effective safety program. Use these safety measures, along with the service bulletins, helpful hints and product specification sheets, when installing or servicing Royal equipment.

We recommend that persons servicing our equipment maintain a similar commitment to safety. Only personnel properly trained should have access to the interior of the vender. This will minimize the potential dangers that are inherent in electrical and mechanical devices. Royal has no control over the vender once it leaves the premises. It is the owner or lessor's responsibility to maintain the vender in a safe condition. See installation insert located in the coin box of a new vender for proper installation procedures and refer to the service manual for recommended maintenance procedures. If you have any questions, please contact the Technical Services Department at 1 800 931 9214 (outside North America, dial +1 304 728 7056).

## SAFETY REGULATIONS

- Read the safety segment before installation or service.
- Test for proper grounding before installing to reduce the risk of electrical shock and fire.
- Turn off or disconnect power cord from wall outlet before servicing.
- Only fully trained service technicians should service vender when vender has power.
- Remove any product before moving a vender.
- Use appropriate equipment when moving a vender.
- Always wear eye protection, and protect your hands, face, and body when working near the refrigeration system.
- Use only authorized replacement parts.
- Be aware of inherent dangers in rocking or tipping a vender.

## SECTION I: ELECTRICAL HAZARDS GENERAL ADVICE

Careless or improper handling of electrical circuits can result in injury or death. Anyone installing, repairing, loading, opening, or otherwise servicing a vender should be aware of this precaution. Apply all of the normal precautions when handling electrical circuits, such as:

- Refrigeration servicing to be performed by qualified personnel only.
- Unplug the vender before servicing.
- Replace electrical cords if there is any evidence of fraying or other damage.
- Keep all protective covers and ground wires in place.
- Plug equipment into outlets that are properly grounded and polarized (where applicable), and protected with fuses or circuit breakers of the correct size.
- All electrical connections must be dry and free of moisture before applying power.

**WARNING: ALWAYS TEST TO VERIFY PROPER GROUNDING PRIOR TO INSTALLATION IN ORDER TO REDUCE THE RISK OF ELECTRICAL SHOCK AND FIRE**

# Safety Segment

---

## SECTION II: ELECTRICAL HAZARDS

### A. Servicing with Power Off

For maximum safety, unplug the power cord from the wall outlet before opening the vender door. This will remove power from the equipment and avoid electrical hazards. Service personnel should remain aware of possible hazards from hot components although electrical power is off.

### B. Servicing with Power On

Some service situations may require access with power on. Only fully qualified service technicians should perform power-on servicing. Particular caution is required in servicing assemblies that combine electrical power and mechanical movement. Sudden movement (to escape mechanical action) can result in contact with live circuits and vice versa. It is therefore important to maintain maximum clearances from both moving parts and live circuits when servicing.

### WARNINGS:

**1. ONLY FULLY TRAINED PERSONNEL SHOULD ACCOMPLISH "POWER-ON" SERVICING. SUCH SERVICE BY UNQUALIFIED INDIVIDUALS CAN BE DANGEROUS.**

2. LIGHTING CIRCUITS CAN BE HAZARDOUS. ALWAYS DISCONNECT VENDER FROM THE WALL OUTLET BEFORE REPLACING A BULB OR SERVICING THE VENDER IN THAT AREA.

3. NEVER USE A HOSE, PRESSURE WASHER OR ANY CLEANING METHOD THAT COULD WET ELECTRICAL COMPONENTS. SEE CLEANING SECTION OF MANUAL FOR SUGGESTED CLEANING METHODS. IF WATER CONTAMINATION OF ELECTRICAL COMPONENTS IS SUSPECTED, USE QUALIFIED ELECTRICAL TESTING EQUIPMENT AND TEST METHODS TO ASSURE THAT VENDER IS NOT A HAZARD BEFORE APPLYING POWER FOR ANY REASON.

# Section 1. General Information

## General Information

### INTRODUCTION TO MERLIN IV

The MERLIN IV can and bottle vender is capable of vending most packages. It uses an electronic control board to manage vending operations. This control board must be programmed correctly for the vender to operate properly. Through the vender's electronic control board, you will find better space to sales allocations which will increase profits through fewer sold out selections and less loading frequency.

Through MERLIN IV's flexibility, you will profit by using the Multi-Pricing and Space to Sales features. As you will see later in the manual, there are other features, such as the ability to control vending by using a "built in" timer or by using an optional on/off key switch. Like most electronic equipment, the control board has the ability to control most items in the vending machine. It manages the operation of the refrigeration system, and even the lighting system, with an optional kit. MERLIN IV utilizes high torque 24-volt DC vend motors. Testing has proven these vend motors to be very strong and reliable.

MERLIN IV's programming is done "Menu Style" with the menus consisting of "Main Items" and "Sub-Items." Figure 1.1 is a good example of how the menu system works.

"Cash" is the first menu after pressing the mode button on the control board. You can only access menu items from the menu you are in. Just as the "ENTER" button takes you into each level, the "HOME" button takes you back to previous menu levels each time you press it. The menu system is explained in greater detail in *Section 4. Vender Programming: Menu Levels.*

# Merlin IV

### MERLIN IV FEATURES

- Field proven, reliable impact delivery sensor detects the vend to cancel vend cycle.
- Patented learning mode for quick vending.
- A "direct drive" DC vend motor in each column drives each column's vend rotor.
- No vend mechanism adjustments are necessary to change from 12 oz. cans to 16 oz. or 20 oz. bottles. All that is needed is to change the depth setting in the programming and product retainers / rear spacers adjustments.
- User-friendly menu style programming.
- Hand Held Computer (HHC) programming and data retrieval.
- Real time clock / calendar to control "built-in" timer (can display time on LED).
- MERLIN IV supports Multi-Drop Bus coin mechanisms, bill validators, and card readers.
- Allows programmable space to sales: custom or factory settings.
- Capable of setting full escrow to vend (even if a column jams).
- External menu allows access to sales (vend) counts and error information.
- Both total (historical) and individual (resettable) vend and cash counters.
- MERLIN IV can display the sale (vend) and cash totals (historical) on the LED upon opening the vender's main door for easy access.

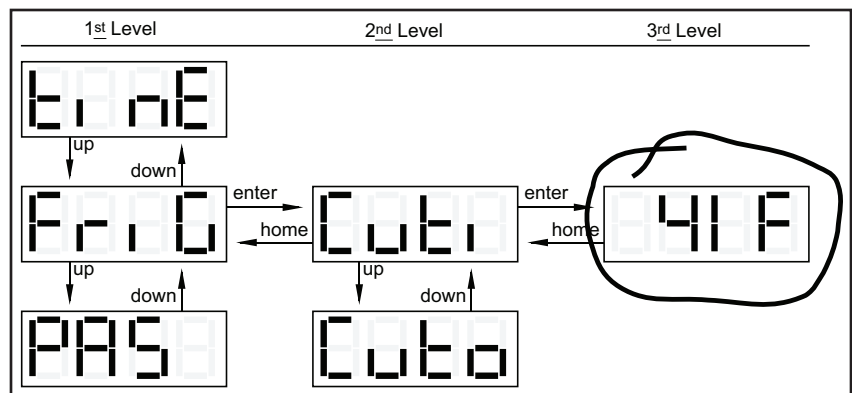

Figure 1.1. Merlin IV menu levels.

# Section 1. General Information

## VENDER IDENTIFICATION

Your MERLIN IV vending machine can be easily identified by taking note of the following three items:

1. Vender serial plate - mounted on the exterior left side of the vender door,
2. Refrigeration serial plate - mounted on the “kick plate” of the refrigeration unit, and
3. Control chip revision number - mounted on the right side of the control board.

### VENDER SERIAL PLATE

**Note:** There are two styles of serial plates issued. See figures 1.2 and 1.3.

VENDER SERIAL PLATE - The vender’s main serial plate (shown in figures 1.2 and 1.3) is located on the exterior left side of the vender’s main door and has the following information:

- Vender model number
- Vender serial number
- Amps required by vender
- Unit charge of R134a
- Refrigeration design pressures

The vender’s model number contains two important pieces of information: the machine type, such as RVCDE (Royal Vendors Cold Drink Electronic); and the vender model number, such as 650-10 (capacity of 650 twelve-ounce cans / 10 selections).

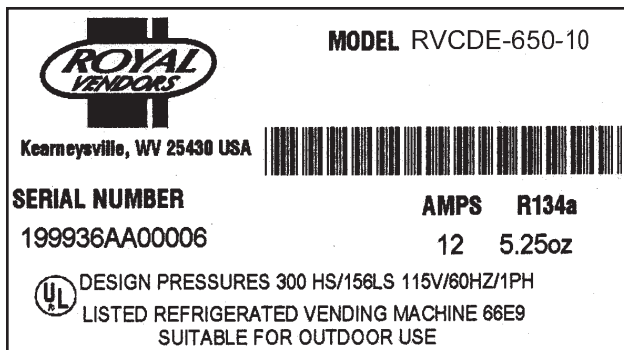

Figure 1.2. Current vender serial plate.

### How to read the newer-style serial number (figure 1.2):

- The first four numbers represent the year the vender was produced.
- The fifth and sixth numbers represent the week within the year the vender was produced.
- The first letter represents the style of vender.
- The second letter represents the location the vender was built.
- The last five numbers represent the model built with in that week.

### How to read the older-style serial number (figure 1.3):

The older-style serial number contains three important pieces of information: the production run number, such as 1466; a date code, such as BK; and the vender number from within the run, such as 01489. The first letter of the date code (B) represents the quarter of the year that the vender was produced:

A = Jan., Feb., Mar.                      **B = Apr., May, Jun.**  
 C = Jul., Aug., Sept.                     D = Oct., Nov., Dec.

The second letter of the date code (K) represents the year that the vender was produced:

A = 1988	B = 1989	C = 1990	D = 1991
E = 1992	F = 1993	G = 1994	H = 1995
I = 1996	J = 1997	K = 1998	L = 1999
M = 2000	N = 2001		

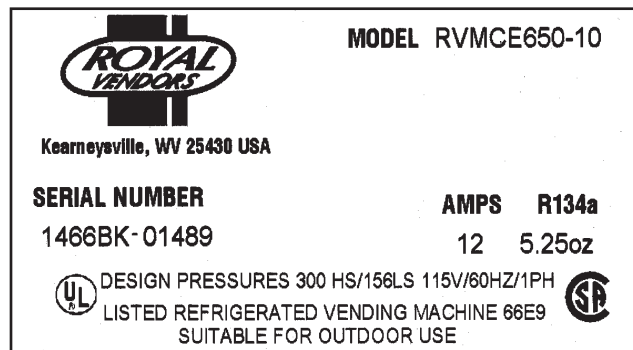

Figure 1.3. Older style vender serial plate.

# Section 1. General Information

---

## REFRIGERATION SERIAL PLATE

The refrigeration serial plate is located at the bottom of the vender's cabinet in front of the condenser coil. It is mounted to the refrigeration unit kick plate. It looks similar to the serial plate shown in Figure 1.2, with the exception that the model number specified is the refrigeration unit model (as shown below). There is currently one model in use:

Model	Compressor Size	Usage
8000W	Super 1/3 Horsepower	All MERLIN IV Venders

## CONTROL CHIP VERSION NUMBER

The control chip version number is printed on a white decal located to the top right of the main chip of the control board. This number is extremely important when calling for service / programming help, or for matching a replacement control board. *See figure 2.2.*

**IMPORTANT NOTE:** To serve you better, we ask you have the following items available before contacting your Royal Vendors service representative:

- A. Your company's name
- B. Your company's telephone number
- C. Your first and last name
- D. The vender's model number
- E. The vender's serial number
- F. The vender's control board revision number (if concerning a board or programming)

It is also very important to have all of the information about your problem available when you call.

## VOLTAGE REQUIREMENTS

The vender is designed to operate at a voltage of 115 volts, 60 hertz. It requires a minimum of 15 amp service. The service outlet voltage must not exceed 129 VAC or fall below 103 VAC. The vender has a three prong, three wire, grounding cord. The vender must be plugged into a grounded electrical outlet to protect the customer from an electrical shock. If you are not sure your outlet is properly grounded, have it checked by a qualified electrician.

When you plug in the vender, you should observe the following:

1. The fluorescent lights displaying the vender sign will illuminate.
2. The refrigeration compressor will start to run after approximately 5-7 minutes (*with the door closed*).
3. The LED display will light.

## VENDER POWER CORD NOTE

Extension cords are not recommended, unless they are authorized before use by a certified electrician.

## Section 2. Vender Component Explanation

---

# Vender Component Explanation

### VENDER CONTROL BOARD (including pinouts)

Your MERLIN IV vender is equipped with a main control board which is responsible for most vender operations. In most venders (non-CDC), it is located in the upper section of the select panel inside the vender's main door. The control board is protected by a cover. Removing this cover will expose the control board in its entirety, along with all of the control board's wiring connections.

**IDENTIFICATION:** The MERLIN IV control board can easily be identified by noting the identification number printed on a small white decal on the control board's EEPROM chip. The control board's identification number is a necessity when ordering parts for your vender and when contacting a Royal Vendors service representative. The control board identification decal is shown in "Vender Identification" of Section 1.

**OPERATION REQUIREMENTS:** The control board requires approximately 24 volts AC from the low voltage transformer (described later in this section). This will allow the control board to function and to supply power to all the vender's components listed below.

**OPERATION:** Upon receiving the appropriate voltage from the transformer, the control board will issue information to some components, receive information from some components, and communicate both ways with some components.

- The control board issues instructions (and / or voltage) to:
  - LED display
  - Vend motor (only when vend motor is to run)
  - Refrigeration relay (for use with electronic refrigeration control)
- The control board receives information (and / or voltage) from:
  - Select switches (logic level)
  - Door switch (logic level)
  - Delivery chute sensor
  - Temperature sensor (for use with electronic refrigeration control)
- The control board communicates both ways with:
  - Coin mechanism
  - Bill validator (optional)
  - Debit card reader (optional)
  - Hand Held Computer (optional)

**CONTROL BOARD PINOUTS:** The MERLIN IV control board has several electrical pinouts, a set-up mode button, a delivery sensor adjustment trimpot, a delivery sensor adjustment indicator lamp, and various other electronic components (all of which have designated position codes). The following section outlines all the control board's pinouts by showing for each:

- The pinout position code as found on the control board (example: P15);
- The name / purpose of the pinout (example: 24-volt power connection);
- A paragraph describing in detail the pinout's purpose and its function; and
- A table describing the pin number, wire number, and function of each position.

The word *key* refers to the small plastic insert plugged into a position of the connector. The purpose of the key is to prevent connecting the harnessing backwards or upside-down. The "keyed position" is a blank position within the pinout (no pin) in which a key is inserted. Some pinouts may have several blank positions with a key plugged into one or more of the positions. You can use the key to determine which end of the pinout is pin 1.

## Section 2. Vender Component Explanation

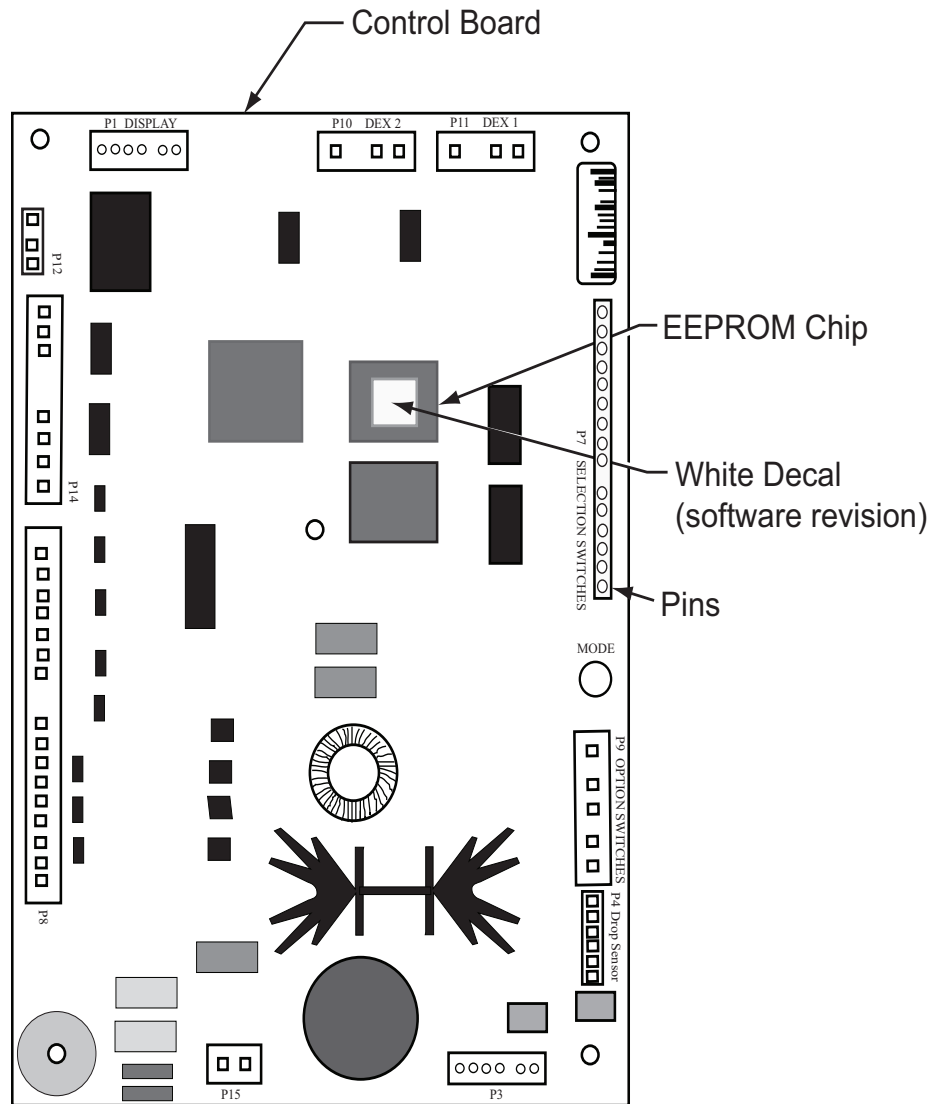

*Figure 2.1. Merlin IV control board layout and EEPROM location.*

### MERLIN IV CONTROL BOARD

Standard LED Display Interface (Position P1): The four (4) wire harnesses connecting to this pinout travel from the vender's LED to the control board. It allows the control board to send power to and communicate with the LED. If this harness is cut or disconnected, the LED will go blank. If this harness is pinched, you may see "broken segments" on the LED with various segments of the display lit.

PIN NUMBER	WIRE COLOR	FUNCTION
1	YELLOW	5 VDC POWER
2	GREEN	DISPLAY CLOCK
3	BROWN	DISPLAY DATA
4	RED	DISPLAY 5 VDC RETURN TO COMMON

## Section 2. Vender Component Explanation

**Multi-Drop Bus (Position P3):** The five (5) wire serial harness connecting to this pinout provides power and communications to and from the control board for the coin mechanism, the optional 24-volt bill validator, and / or the optional debit card reader. If this harness is cut, pinched, or disconnected, you will noticeably lose power to the coin mechanism.

PIN NUMBER	WIRE COLOR	FUNCTION
1	WHITE	MDB 35 VOLTS DC UNREGULATED
2	BROWN	MDB 35 VOLTS DC RETURN TO COMMON
3	KEY	KEY
4	BLACK	VMC RECEIVE/ MDB TRANSMIT
5	RED	VMC TRANSMIT/ MDB RECEIVE
6	GREEN	VMC/MDB COMMON
7	BLUE	NOT USED

**Delivery Sensor (Position P4):** The two (2) wire harness connecting to this pinout is a grey, shielded cable harness. It should never be cut, pinched, or spliced. This harness is formed into the impact sensor (mounted beneath the center of the delivery chute). It travels through the bottom of the vender's main door to the control board.

PIN NUMBER	WIRE COLOR	FUNCTION
1	-	NOT USED
2	-	VMC COMMON (2.5DC) RETURN TO GROUND
3	RED	DROP SENSOR OUTPUT #1
4	BLACK	DROP SENSOR OUTPUT #2
5	-	VMC COMMON RETURN TO GROUND
6	-	NOT USED

**Selection Switches (Position P7):** The wiring harness connecting to this pinout carries a logic level (ground) signal from pin 11 of the control board to the common position of each select switch. Upon activation, the select switch will allow the logic level signal to travel back to the control board. This will tell the control board a particular switch is activated.

PIN NUMBER	WIRE COLOR	FUNCTION
1	WHITE	SEL SWITCH #9
2	YELLOW	SEL SWITCH #8
3	ORANGE	SEL SWITCH #7
4	GREEN	SEL SWITCH #6
5	BLUE	SEL SWITCH #5
6	BROWN	SEL SWITCH #4
7	PURPLE	SEL SWITCH #3
8	GREY	SEL SWITCH #2
9	BLACK	SEL SWITCH #1
10	KEY	KEY
11	RED	COMMON
12	-	SEL SWITCH #12
13	-	SEL SWITCH #11
14	PINK	SEL SWITCH #10

**Vend Motors (Position P8):** The fourteen (14) wire harness connecting to this pinout provides common power from the control board to each vend motor. There is one wire in this harness for each vend motor to provide each motor with 24 volts DC, when a selection is made. Be sure that this harness is properly grounded.

PIN NUMBER	WIRE COLOR	FUNCTION
1	GREEN	VEND MOTOR #1
2	RED	VEND MOTOR #2
3	YELLOW	VEND MOTOR #3
4	ORANGE	VEND MOTOR #4
5	BROWN	VEND MOTOR #5
6	BLUE	VEND MOTOR #6
7	GRN / WHITE	VEND MOTOR #7
8	RED / WHITE	VEND MOTOR #8
9	YLW / WHITE	VEND MOTOR #9
10	KEY	PP
11	ORNG / WHITE	VEND MOTOR #10
12	BR / WHITE	VEND MOTOR #11
13	BLUE / WHITE	VEND MOTOR #12
14	BLACK	VEND MOTOR COMMON (Source)
15	GRN / YLW	GROUND

## Section 2. Vender Component Explanation

**Features Connection (Position P9):** The wiring harness connecting to this pinout travels from the vender's door switch through the bottom of the vender's main door and to the control board. Pinout P9 is also used for the optional "free vend" and "no vend" key switch kits.

PIN NUMBER	WIRE COLOR	FUNCTION
1	WHITE	FEATURE PLUG/ SWITCH COMMON
2	-	KEY
3	(OPTIONAL)	FREE VEND SWITCH INPUT
4	(OPTIONAL)	NO VEND (VEND DISABLE) INPUT
5	(OPTIONAL)	OPTION SWITCH INPUT
6	PURPLE	DOOR SWITCH INPUT

**DEX UCS Connection (Position P10):** The three (3) wire harness connecting to this pinout comes from the Hand Held Computer jack, located inside the vender's main door (near the control board). The Hand Held Computer (HHC) plugs into this jack to read and write information from the vender's control board. If the HHC is not operating properly, check this harness for bad connections at the solder joints. Also check to ensure the insulator is not cracked from over tightening.

PIN NUMBER	WIRE COLOR	FUNCTION
1	RED	VMC TRANSMIT/DEX RECEIVE DATA (TIP)
2	-	KEY
3	WHITE	VMC RECEIVE / DEX TRANSMIT DATA (RING)
4	GREEN	DEX COMMON

**DEX UCS Connection (Position P11):** The three (3) wire harness connecting to this pinout comes from the external Hand Held Computer jack located on top of the welded port assembly. The Hand Held Computer plugs directly into this jack while the vender's main door is closed to read information from the vender's control board. Information cannot be written to the vender's control board unless the vender's door switch is in the "door open" position. If the HHC does not operate properly, check the harness for bad connections at the solder joints. Also check to ensure the insulator at the jack is not cracked from over tightening.

PIN NUMBER	WIRE COLOR	FUNCTION
1	RED	TRANSMIT / DEX RECEIVE DATA (TIP)
2	-	KEY
3	WHITE	RECEIVE / DEX TRANSMIT DATA (RING)
4	GREEN	DEX COMMON

**Primary Temperature Sensor (Position P12):** The wiring harness connecting to this pinout travels from the temperature sensor to the control board. The temperature sensor is mounted on the rear tank above the evaporator fan. This harness is molded into the temperature sensor and should never be cut, pinched, or spliced together if cut. If the harness is cut, pinched, or improperly grounded, the sensor may give the control board false temperature readings. Refrigeration activity is based on the signal reported to the control board from this sensor (pin 2).

PIN NUMBER	WIRE COLOR	FUNCTION
1	BLACK	TEMP. SENSOR 5 VOLT DC SUPPLY
2	KEY	KEY
3	WHITE	TEMP. SENSOR SIGNAL
4	RED	TEMP. SENSOR 5 VOLT RETURN TO COMMON

## Section 2. Vender Component Explanation

---

Auxiliary Temperature Sensor (Position P13): This pinout may be available in the future, but as of this service manual printing it is not available.

PIN NUMBER	WIRE COLOR	FUNCTION
1	-	-
2	-	-
3	-	KEY
4	-	-

Environmental Controls (Position P14): The wiring harness connecting this pinout powers the refrigeration relay (to power the refrigeration unit). It is also responsible for powering any optional relays, such as the heater relay, evaporator fan relay, illumination (sign lighting) relay, and a 24-volt DC counter. It powers each relay and counter by providing a constant 24 volts DC to each relay from pin 1. Upon activation, the control board will remain neutral for each relay, or counter, from either pins 2, 3, 4, 6 or 7.

PIN NUMBER	WIRE COLOR	FUNCTION
1	2X1	24 VDC
2	2X2	HEATER RELAY
3	2X3	COMPRESSOR RELAY
4	2X4	FAN RELAY
5	KEY	FAN RELAY OUT
6	2X6	FLUORESCENT LIGHT RELAY
7	-	IMPULSE COUNTER
8	-	24 VDC

24 Volt AC Power In (Position P15): The two (2) wire harness connecting this pinout come from the low-voltage transformer. It is imperative the correct harness be connected to this pinout. If this harness is not connected (or if power is lost to this connection), the vender will noticeably lose all functions (except main door lighting), including power to the LED display. The coin mechanism will not accept coins. The compressor and condenser fan motor also will not run. With this connector, the wire harness can be in either position and the control board will not be affected.

PIN NUMBER	WIRE COLOR	FUNCTION
1	-	24 VOLT AC
2	-	NEUTRAL

## Section 2. Vender Component Explanation

---

### LOW VOLTAGE TRANSFORMER

**(Run 1476 and after will have a fuse between the transformer and the control board)**

The MERLIN IV vender uses a low-voltage (75 VA) transformer which reduces 115 volts AC (conventional voltage) to 24 volts AC, to power the vender's control board. The transformer is a major contributor to the vender's operation. Without the transformer, the control board cannot function.

**LOCATION OF TRANSFORMER:** In a CDC (Center Door Changer) vender, the transformer is located below the control board. The fuse is fastened to the changer plug bracket. In a non-CDC vender, the transformer and fuse are located at the top of the main door.

**OPERATION:** The transformer has a three (3) amp external fuse on a secondary circuit to protect the control board and the coin mechanism. If the transformer fuse blows, you will lose power to the control board, noticeably cutting power to the LED display, and also cutting power to the coin mechanism and bill validator. If you have a problem similar to this, follow the procedures listed below.

**OPERATION REQUIREMENTS:** The transformer operates by receiving 110 volts AC from the Vender (black and red wires). It transforms the 110 volts AC into 24 volts AC which is what the Control Board requires for its operation.

**CHECK THE TRANSFORMER AND FUSE:** If upon arriving at a vender, the LED display is not lit and the coin changer does not take coins or pay out coins, make sure the vender is plugged in. Next, check the transformer's external fuse for visual damage. Check for continuity across the fuse with a voltage meter or similar device. If defective, replace the external fuse.

*Note: Merlin IV venders made before run 1476 use an internal fuse in the transformer.*

1. Check the power going into the transformer at the connected red and black wires. It should register 115 volts AC. If not, check all wiring leading up to this point from the bottom of the vender's main door. The transformer may not be the problem. There may be a broken wire or a bad connection.
2. If 115 volts is registered during Step 1, measure voltage at the other end of the transformer. The two-pin connector at the control board connected to position P15 should register approximately 24 volts AC at this end of the harness. If so, check the control board; the transformer is good.
3. If 115 volts is registered during Step 1 and 24 volts AC is not registered during Step 2, the vender has a bad transformer. Unplug the vender and transformer connections at the transformer (115-volt side). Unplug the transformer from the control board and remove it from the vender's main door by locating the side of the transformer that has two built-in wires going into the plastic housing.

## Section 2. Vender Component Explanation

---

### DELIVERY CHUTE SENSOR

**ADJUSTMENT:** Located below the sensor connector is the sensor adjustment trimpot, which includes an adjustment screw. The trimpot is used to adjust and fine-tune the sensor. It is capable of turning both clockwise and counterclockwise. Located directly above the trimpot is the sensor adjustment LED indicator light. The indicator light is mainly used to aid in adjusting the sensor but can also be used to test its operation during product impact.

1. Turn the adjustment screw clockwise until the indicator light comes on.
2. Turn the screw counterclockwise until the light just goes out.
3. Continue to turn the screw counterclockwise one turn. **Note:** *Slight adjustments may be needed outside the factory set one turn. Turning the adjustment screw clockwise makes the sensor more sensitive and counterclockwise makes it less sensitive. Test vend after every 1/4 turn.*

For multiple-vending from all columns, make sure the sensor is adjusted to the factory specifications as listed above. Next, turn the adjustment screw clockwise 1/4 turn to increase sensitivity. Test vend columns 7 and 12, and watch the light on the board for a good on and off flash. If still multiple-vending, turn the adjustment screw an additional 1/4 turn clockwise until proper adjustment is made.

For dry-vending from all columns, make sure the sensor is adjusted to the factory specifications as listed above. Next, turn the adjustment screw counterclockwise 1/4 turn to decrease sensitivity. Test vend all columns. If still dry-vending, turn the adjustment screw an additional 1/4 turn counterclockwise until proper adjustment is made.

**TESTING THE DELIVERY CHUTE SENSOR:** Make sure the vender is plugged in and the controller has power (the LED display on the front of the vender will be lit and the coin mechanism will accept coins). The sensor indicator light will blink upon impact on the delivery chute. Lightly tap the chute with a tool, or your fist, to simulate a can drop.

1. Locate the Sensor Adjustment Indicator Lamp on the lower right corner of the Vender's Control Board. Under normal conditions (as in stand-by), the lamp should be off.
2. Test the sensor by vending from column 7 and 12 while watching the Control Board's Sensor Adjustment Indicator Lamp. The light should blink solidly upon impact. If not, turn the sensor adjustment screw clockwise in 1/4 turn increments (to increase the sensitivity) and test after each turn. If the indicator lamp still does not light, turn the adjustment screw clockwise for many turns. If the indicator lamp does not light, change the sensor (assuming the Control Board has power and is working).
3. If the Sensor Adjustment Indicator Lamp lights properly during Step 2, change the Control Board.
4. Test the sensor by hitting the center of the delivery chute while watching the control board's sensor adjustment indicator light. The light should blink solidly upon impact.

## Section 2. Vender Component Explanation

---

### REFRIGERATION SYSTEM

The vender's refrigeration system is responsible for the cooling of the cabinet and the products loaded within it. The refrigeration system comes as a completely sealed unit and should never be cut or tapped into, or the warranty will be voided.

OPERATION REQUIREMENTS: The refrigeration system requires 115 volts AC from the main wiring harness for it to operate. The main wiring harness will get its voltage for the unit from the refrigeration relay.

HEALTH SENSOR OPERATION (if enabled): The rising temperature in the cooling compartment is reported to the control board by the temperature sensor. At power up, the controller will check for the temperature. If the temperature is above 41°F (5°C), the vender will display "Out of Order." Once the "h5" error has been cleared, a 30-minute timer will begin. At the end of this 30 minutes, the vender will stay in normal operating mode as long as the temperature remains 41°F (5°C) or below. If the vender is 41°F (5°C) or below at power up, the vender will stay in normal operating mode. If the door is open after power up and the temperature is 41°F (5°C) or below and stays at 41°F (5°C) or below, a 30-minute timer will start after the door is closed. If the temperature is above 41°F (5°C) after 30 minutes, the vender will display "Out of Order." Any time the vender is in a normal operating mode and the temperature reaches above 41°F (5°C), a 15-minute timer will start. If after 15 minutes the temperature remains above 41°F (5°C), the vender will display "Out of Order."

REFRIGERATION COMPONENTS: The refrigeration system is a sealed system. Described in this section are explanations of the refrigeration system's major components.

**Compressor** - The compressor is an hermetically-sealed unit located beneath (outside) the cooling compartment. The compressor is a pump, driven by the compressor motor which draws low-pressure vapor (refrigerant) from the evaporator coil, compresses it, and forces it into the condenser under high pressure. The motor is started and controlled by the refrigeration relay.

**Condenser** - The condenser is located beneath (outside) the cooling compartment next to the compressor. It can be seen from the front with the door open. The condenser removes heat from the high-pressure vapor discharged from the compressor and condenses it to a high-pressure liquid. The condenser and evaporator coils have aluminum fins attached to effectively increase heat exchange surfaces.

**Starting Relay** - The starting relay is mounted on the side of the compressor housing. The compressor motor has two windings (start winding and run winding). To give the motor torque when it first starts, the starting relay switches in the additional start winding. After the motor gets up to speed, the relay opens the start winding and the motor continues using only the run winding.

**Thermal Overload** - The thermal overload is a heat-sensitive device mounted on the side of the compressor housing. If the compressor motor gets too hot or draws an excessive amount of current, the thermal overload will open, breaking the circuit to the compressor. After the compressor cools to a safe operating temperature, the thermal overload will close, allowing the compressor and condenser fan motors to restart.

**Condenser Fan and Motor** - The condenser fan and motor, located beneath the cooling department, are a forced-air device using outside ambient air to cool the surface of the condenser coil. The condenser fan and motor run while the compressor operates.

**Evaporator Coil** - The evaporator coil is located in the cooling compartment. As low pressure liquid passes through the evaporator coil, it absorbs and removes heat from the compartment as it changes to vapor. The condenser and evaporator coil have aluminum fins attached to effectively increase their heat exchange surfaces.

## Section 2. Vender Component Explanation

**Evaporator Fan and Motor** - The evaporator fan and motor are a forced-air device circulating air throughout the cooling compartment and over the heat exchange surface of the evaporator coil.

**Drier** - The drier is located in the refrigerant line between the capillary tube and condenser. It traps and removes moisture from the refrigeration system while allowing oil and refrigerant to pass through the system.

**Accumulator** - The accumulator is located in the refrigerant line between the evaporator coil and the compressor. The accumulator traps any liquid refrigerant which did not vaporize before it reaches the compressor.

**Refrigeration Relay** - The refrigeration relay is located in the lower left section of the vender's cabinet near the main wiring harness. The refrigeration relay is responsible for powering the compressor and condenser fan motors. The refrigeration relay consists of a coil powered by the control board (24 VDC) and a switch. When the control board completes the circuit to the refrigeration relay, the relay will energize, closing the contact between the common and the normally-open positions. When this happens, power (115 VAC) travels from the refrigeration relay to the main wiring harness for the refrigeration unit.

### REFRIGERATION CYCLE

1. The rising temperature in the cooling compartment is reported to the control board through the temperature sensor.
2. The control board registers the current temperature inside the vender's cabinet. When it rises equal to or above the pre-programmed cut-in temperature, the control board will complete the circuit to the refrigeration relay to energize its coil.
3. The refrigeration relay coil closes the contact between the common and normally-open positions, allowing 115 volts to travel to the main wiring harness to start the compressor.
4. The compressor circulates refrigerant throughout the system by pulling low-pressure refrigerant vapor from the evaporator coil, compressing it, and forcing it into the condenser. The condenser, aided by the condenser fan motor, removes heat from the refrigerant as it flows through the condenser and releases it to the outside environment. The dropping of the refrigerant temperature changes the vapor to liquid.
5. The evaporator coil allows the liquid refrigerant to absorb heat from the cooling compartment as it evaporates in the coil.
6. The falling temperature in the cooling compartment is caused by the continual circulation of refrigerant through the system, removing heat from the cooling compartment and transporting it to the outside environment. When the temperature drops, the

temperature sensor reports this to the vender's control board.

7. When the temperature drops below the preset cut-out temperature, the control board will disable the refrigeration relay, thus killing power to the refrigeration unit.

### REFRIGERATION SYSTEM

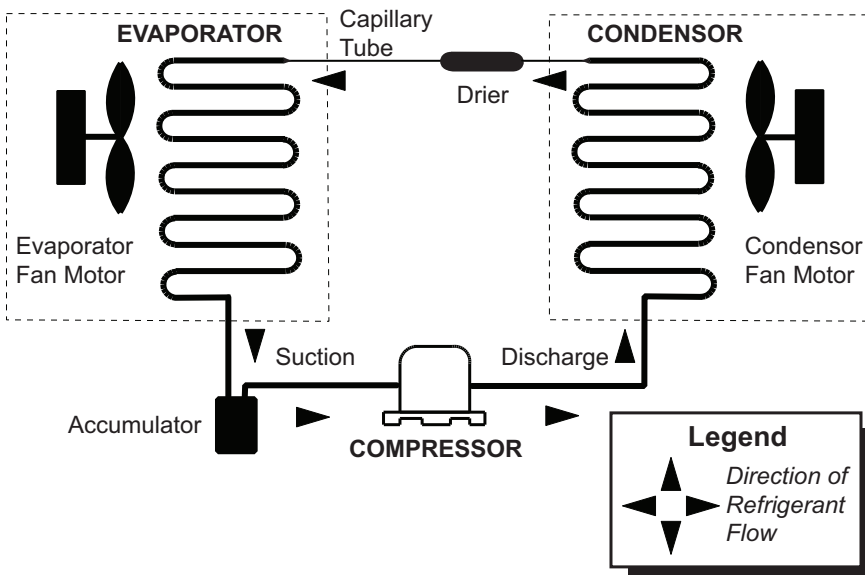

*Figure 2.2. Refrigeration System Flow*

## Section 2. Vender Component Explanation

---

### TESTING THE REFRIGERATION SYSTEM

1. The sealed refrigeration unit can be tested by unplugging it from the top of the main wiring harness and plugging it directly into a power source. If the unit still does not operate, a problem exists within the sealed unit.
2. If the sealed unit runs when plugged into an external power source, the problem more than likely lies between the control board, the refrigeration relay, and the main wiring harness.

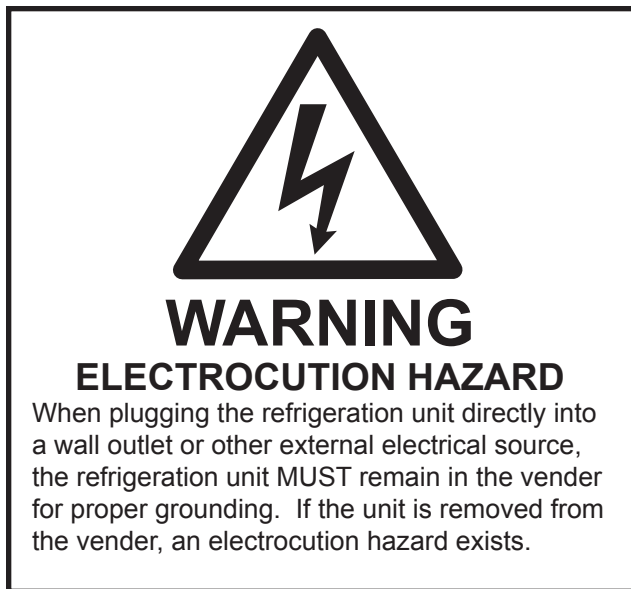

### BALLAST

The ballast acts as a transformer to convert conventional voltage (115 VAC) to a higher voltage required to energize the vender's fluorescent lights. The ballast is located inside the vender's door, behind a metal panel. To remove the ballast from the door, use a Phillips screwdriver to remove the screws that mount the ballast to the door chassis.



**WARNING:** Before removing the ballast, remove power from the vender by unplugging the main power cord from the AC voltage power source!

### CREDIT PERIPHERALS

There are three possible credit peripherals for the Merlin IV vender: the coin changer, bill acceptor, and debit card reader. The coin changer determines the validity and value of each coin that is inserted into the vender and sends the coin information to the controller. The coin changer also continuously informs the controller if coins are available in the change tubes to be used for change payout. The bill acceptor determines the validity and value of each bill that is inserted and sends that information to the controller. The debit card reader allows customers to purchase a product using a debit or credit card. For detailed information on any of the credit peripherals, refer to the separate operation and service manual provided by the peripheral's manufacturer.

# Section 3. Vender Programming

## Vender Programming

### THE NECESSITY OF CORRECT PROGRAMMING

The MERLIN IV vender must be programmed correctly for it to operate properly. Improper programming could potentially cause the following problems:

MODE	PROBLEM SEEN
Pr1 ₤	Wrong prices, free vending
Sto5	Columns not vending or wrong columns vending
Con	Vender options such as forced vend / escrow not working properly
SdEP	Vender multiple vending or long vend cycles
StEL	If enabled with use of timer or key switch, will disable selections
brnE	Will disable selections or Refrigeration System if turned on
Fr1 5	Will keep the unit from running or allow warmer / colder temperatures
PR5	Will keep you from accessing the external password mode
LFR5	Will display different languages for display messages

### PRECAUTIONS TO TAKE WHEN WORKING WITH CONTROL BOARD

As with any printed circuit board, our electronics are very sensitive to electrostatic discharge (ESD). Simply walking across a tile, or carpeted floor, can generate a range of 30,000 to 50,000 volts of electricity. One ESD can be enough to seriously damage your control board, or at least weaken it enough that erratic problems could occur in the future. Even a discharge surge under 100 or 200 volts is enough to create shorts or other problems within the circuitry of the electronics. It is advised when storing the electronics that they be kept in their anti-static bags, even if the electronics are thought to be defective. If a control board is thought to be defective and is really not, it soon will be after being charged with ESD. The ideal prevention against ESD is to use anti-static conductive wrist straps which ground you to the machine before touching the electronic boards. If it is not possible to use these, at least ground yourself before handling the electronic boards. Whatever method you use, always handle the electronic boards by the edges. Be careful not to touch the components on the control board.

### INTRODUCTION TO PROGRAMMING

As mentioned earlier in "The Necessity Of Correct Programming," it is very important your vender is programmed properly. To do this, you must understand how the system works and what it takes to program your vender. As you will see, after you are able to program one or two modes, you will be able to use similar procedures to program all modes.

MANEUVERING THROUGH LEVELS - The first step to understanding MERLIN IV programming is to learn how to negotiate through and around the menu levels to accomplish your task. To maneuver through the menu levels, you must use the select buttons on the front of your vender. Certain buttons have different meanings. You will use these buttons to move up or down through the menus. You will also use certain buttons to enter a new menu level or to exit back to a previous level. These four meanings that we have just mentioned are listed below, along with the active button for each.

*NOTE: Programming Flowchart located in rear of manual.*

BUTTON	MEANING	FUNCTION
1	UP	Increase, Next, Etc.
2	DOWN	Decrease, Previous, Etc.
3	ENTER [press and release, less than two seconds]	Save, Accept, OK, Etc.
3	HOME [press & hold for two seconds or greater]	Exit, Escape, Return, Etc.

MENU SYSTEM - When programming, you must first use the three programming buttons listed above to maneuver through menus and sub-menus before you will be allowed to accomplish your task. Each menu consists of various items, or modes, such as "Pr1 ₤" (Selection Price Setting Mode) or "Sto5" (Space-to-Sales Setting Mode). There are currently two different main menus available.

## Section 3. Vender Programming

1. **INTERNAL (Service) MENU:** This menu is available only with the vender's main door open. It is accessed upon pressing the control board's mode button. This menu contains all the programming modes, such as the Selection Price Setting Mode and Space-to-Sales Mode.
2. **OPTIONAL MENU:** This mode is available when Configuration 2 (C2) is set to "1."

### Menu Levels

**NOTE:** The order of the submenus will be somewhat different from the following on board revisions prior to 67100-X. Refer to the programming flowcharts at the end of the manual for older revisions.

#### INTERNAL (Service) MENU

##### MODE DESCRIPTION

CASH	Cash Counter Mode: Used to access the total and individual cash counts.
SALE	Sale Counter Mode: Used to access the total and individual vend counts.
CARD	Card Counter Mode: Used to access the cash and sales counts of all card vends.
TOKEN	Token Counter Mode: Used to access the cash and cost counts for all token vends.
FREE	Free Vend Accounting: Used to access the cash and cost counts for all free vends.
ERROR	Errors Mode: Used to read and clear vender errors.
TEST	Test Vend Mode: Used to free test vend from columns .
PRICE	Price Setting Mode: Used to program selection prices.
SPACE	Space to Sales Mode: Used to program columns to vend from select buttons.
DEPTH	Set Vending Depth: Used to program vending depth per selection.
CONF	Configurations Mode: Used to set vender options.
RTN	Return to Sales: Used to return to the sales (greeting) mode (if Con 2 is set to "0").

#### Optional Menu (if Con 2 is set to "1")

ECO	Exact Change Only Mode: This mode controls the Exact Change Only light.
COIN	Coin Payout Mode: Used to payout coins from coin mechanism.
TUBE	Tube Fill Mode: Used to fill coin mechanism tubes.
DISC	Discounted Sale Counter: Used with discount prices or free vend switch.
DIFF	Discounted Differential Cash Counter: Used with discount prices or free vend switch.
SDIS	Set Discount Pricing: Automatically reduces vend prices during the day (uses timer).
SETC	Set Timer Controlled Selections: Used to choose the selections to turn on / off.
TIMER	Timer Mode: Used to program on / off times for selections, refrigeration and lighting.
REFR	Refrigeration Mode: Used to adjust temperatures and test refrigeration operation.
PASS	External Password Mode: Used to set a password to access External Menu
LANG	Language Mode: Used to change the display to different languages.
RTN	Return to Sales: Used to return to the sales (greeting) mode (door closed state).

#### EXTERNAL MENU

##### MODE DESCRIPTION

SALE	Sale Counter Mode: Used to access the total and individual vend counts.
RTN	Return to Sales: Used to return to the sales (greeting) mode (door closed state).
ERROR	Errors Mode: Used to read and clear vender errors.

# Section 3. Vender Programming

## Internal (Service) Menu

Opening the vender's main door and pressing the control board's service mode button will allow you to access the Internal Menu. This section completely outlines all the Internal Menus, including descriptions and operation instructions for each mode. *After five (5) minutes without activity, the control board will revert to the Sales Mode (the LED will show the greeting).*

**Note: The following menu order pertains to 67100-7 and higher control board.**



### Cash Counter Mode

This mode allows you to manually extract the amount of cash taken into the vender through product sales (up to \$999,999.99). The Cash Counter Mode consists of a total count which is non-resettable. Individual selection counts are resettable, depending upon the proper configuration setting (see Configurations). The counts will be preceded by the count type (CL=cash level) and can be displayed in one (1) or two (2) sets of four (4) digits. Examples for both types of cash counters are:

Count Type	Actual Count	1 <sup>st</sup> Display	2 <sup>nd</sup> Display	3 <sup>rd</sup> Display
Total Cash Count	\$56,789.10	"CASH"	"567"	"89.10"
Selection Cash Count	\$6,789.10	"CL [number]"	"67"	"89.10"

**OPERATION:** If **<enter>** is pressed when the display shows "CASH", the controller will enter the Cash Counter Mode. The display will flash "CASH" and the total amount of cash taken into the vender. This can be shown in two sets of four digits (see Example 1 above). Using **<up>** or **<down>** will cycle through individual selection cash counts for each. The display will flash individual selection counts (as shown in Example 2 above). If **<home>** is pressed anytime during this operation, the controller will return to the "CASH" display. From "CASH" pressing **<down>** will take you to "rtn." Pressing **<up>** will take you to "SALE".

**CLEARING INDIVIDUAL COUNTERS:** If the Configurations Mode is set to allow the individual counters to be reset, the individual counters will reset upon reading at least one of them and closing the vender's main door (actuating the vender's door switch).



### Sale Counter Mode

This mode is very similar to the Cash Counter Mode. The Sale Counter Mode allows you to manually extract the amount of product vended from your vender (up to 99,999,999 vends). The Sale Counter Mode consists of a non-resettable total count and individual selection counts which are resettable, depending upon the proper configuration setting (see Configurations). The counts will be preceded by the count type (SL=sale level) and can be displayed in one (1) or two (2) sets of four (4) digits. Examples for both types of sale counters are:

Count Type	Actual Count	1 <sup>st</sup> Display	2 <sup>nd</sup> Display	3 <sup>rd</sup> Display
Total Sale Count	5,678,910	"SALE"	"567"	"8910"
Selection Sale Count	678,910	"SL [number]"	"67"	"8910"

**OPERATION:** If **<enter>** is pressed when the display shows "SALE," the control board will enter the Sales Counter Mode. The display will flash "SALE" and the total amount of sales made by the vender. This can be shown in two sets of four digits (see Example 1 above). Using **<up>** or **<down>** will cycle through individual selection sale counts. The display will flash individual selection counts (as shown in Example 2 above). If **<home>** is pressed anytime during this operation, the controller will return to the "SALE" display. From "SALE" pressing **<down>** will take you to "CASH." Pressing **<up>** will take you to "CArd."

**CLEARING INDIVIDUAL COUNTERS:** If the Configurations Mode is set to allow the individual counters to be reset, the individual counters will reset upon reading at least one of them and closing the vender's main door (actuating the vender's door switch).

## Section 3. Vender Programming

**CARD**

### Card Counter Mode

*(67100-9 and higher only)*

If **<enter>** is pressed at the “CARD” prompt, the controller will enter the Card Counter Mode. The display will show “CASH” and the total historical amount of money made by sales using a debit or credit card (in the same fashion as shown in Cash Counter Mode, above). Press **<up>** or **<down>** to cycle to the card vend counter display, where the display will show “SALE” and the total historical amount of product sold using a debit or credit card. Note that individual counts for each selection are not available in the Card Counter Mode. If **<home>** is pressed anytime during this operation, the controller will return to the “CARD” display. From “CARD” pressing **<down>** will take you to “SALE.” Pressing **<up>** will take you to “toKn.”

**toKn**

### Token Counter Mode

*(67100-9 and higher only)*

If **<enter>** is pressed at the “toKn” prompt, the controller will enter the Token Counter Mode. The display will show “CASH” and the total historical amount of money made by sales using a vend token (in the same fashion as shown in Cash Counter Mode, above). Press **<up>** or **<down>** to cycle to the token vend counter display, where the display will show “SALE” and the total historical amount of product sold using a vend token. Note that individual counts for each selection are not available in the Token Counter Mode. If **<home>** is pressed anytime during this operation, the controller will return to the “toKn” display. From “toKn” pressing **<down>** will take you to “CARD.” Pressing **<up>** will take you to “FrEE.”

**FrEE**

### Free Vend Accounting

*(67100-10 and higher only)*

This mode is used to track cash counts, sale counts, and cost of all free vends. If **<enter>** is pressed at the “FrEE” prompt, the controller will enter the first of three sub-menus, “CASH.” Pressing **<up>** at the “FrEE” prompt will take you to the next prompt, “Error.”

If **<enter>** is pressed at the “CASH” prompt, the controller will enter the cash value display mode by displaying “CASH” / “XXXX” / “XX.XX,” where the X’s represent the equivalent free vend cash value received over machine life. A decimal will be displayed in the appropriate position with the lower 4 digits; no decimal will be used with the upper 4 digits. If the cash amount is less than 5 digits long, the upper byte is not displayed.

Using **<up>** or **<down>** will cycle through each selection as “SL N” / “XXXX” / “XX.XX,” where “N” will indicate the selection number and the X’s represent the resettable value of free vends. If **<exit>** is pressed anytime during this operation, the controller will return to the “FrEE” prompt.

If **<enter>** is pressed at the “SALE” prompt, the controller will enter the free vend counter display mode by displaying “SALE” / “XXXX” / “XXXX,” where the X’s will represent the number of all free vends over machine life. If the sales amount is less than 5 digits, the upper 4 digits will not be displayed.

Using **<up>** or **<down>** will cycle through each selection as “SL N” / “XXXX” / “XXXX,” where “N” will indicate the selection number and the X’s represent the resettable number of free vends. If **<exit>** is pressed anytime during this operation, the controller will return to the “FrEE” prompt.

If **<enter>** is pressed at the “COST” prompt, the controller will enter the free vend equivalent cost display mode by displaying “SL N” / “XX.XX,” where “N” will represent the selection number and the X’s represent the last saved price for that selection that is not \$00.00. A decimal will be displayed in the appropriate position. Using **<up>** or **<down>** will cycle through each selection. If **<exit>** is pressed anytime during this operation, the controller will return to the “FrEE” prompt.

## Section 3. Vender Programming

### Error

#### Errors Mode

This mode was designed to help diagnose vender problems. Upon opening the vender's main door, the LED will flash any possible errors. (For a list, refer to Section 6, Vender Maintenance: Error Codes.) If there are no errors, the display will flash "none" and after five (5) minutes of no activity will revert to the sales greeting (ICE COLD). The Errors Mode was designed to give a detailed description of each error and allow you to clear errors.

**OPERATION:** If <enter> is pressed when the display shows "Error," the controller will enter into the errors descriptive display mode. At this point, the display will show any and all current vender errors followed by the descriptive errors for each. If no errors exist, "none" will appear on the display but will revert back to the sales greeting after five (5) minutes of no activity. If <home> is pressed anytime during this operation, the controller will return to the "Error" display. From "Error" pressing <down> will take you to "FrEE" and pressing <up> will take you to "tEST."

**CLEARING ERRORS:** To clear an error, wait until the error to be cleared is shown on the LED display. Then, immediately press the <up> or <down> button and hold it in for at least two seconds; the error will disappear. Follow this procedure for each error.

### tEST

#### Column Test Vend Mode

This mode is used to vend test by column, not by selection. After entering into this mode, you will have to pick the column which is desired to be tested. By pressing the <enter> button, the control board will vend from that column. No money is needed. This mode will test the control board's ability to distribute 24 volts DC to the proper vend motor upon command. It will also test the mechanical part of the vending circuit, such as the vend motor and rotor. It does not test the control board's coin acceptance / credit / payout circuit.

**OPERATION:** If <enter> is pressed when the display shows "tEST" the controller will enter the Column Vend Test Mode. The display will show "CO 1" (Column 1). Using <up> or <down> will cycle you through all the available columns to be test vended (the display may show some columns that are not in your vender; nothing will happen if a test vend is attempted from these columns.). If <enter> is pressed, the controller will attempt to test vend from the column which is being displayed. If a vend is not in progress, pressing <home> will return you to the "tEST" display. From "tEST", pressing <down> will take you to "Error". Pressing <up> will take you to "PriC".

*Note: Test vends will not affect cash or sale counters.*

### PriC

#### Selection Price Mode

This mode is used to set vend prices. Depending on the Configurations Mode (discussed later in this section), this mode will allow you to set either single or multi-pricing. When the configurations are set to allow single pricing, only one price has to be set in the "PriC" Mode (not individually). The current price will be displayed on the LED display during the greeting. If the configurations are set to allow multiple pricing (per selection), the display will not show the vend price during the greeting unless all selections are set to the same price. You will have two options when setting prices:

- Single Price – Gives you the option to set one price for all selections.
- Multi-price – Allows you to set a different vend price for each selection.

If a free vend key switch is in use (turned-on), the display will scroll "FREE" during the greeting instead of the normal vend price. (*That is, if all selections are assigned in StCL mode.*)

**OPERATION:** If <enter> is pressed when the display shows "PriC", the controller will enter the price setting mode.

- Single Price Operation: The display will flash "SPri" and the current single price setting. This will be the single price viewing level. If <enter> is pressed again, the display will show the current single price only. If <up> is pressed or held, the price will increase in 0.05 increments. If <down> is pressed or held, the price will decrease in 0.05 increments. After the desired price has been set, press <home> to save your setting and return to the single price viewing level. Pressing <home> from the single price viewing level will return you to the display of "PriC".
- "ALL" Pricing Operation: The display will flash "ALL" followed by the last price set for all selections. If <enter> is pressed at this point, the display will steadily show the current "ALL" price. If <up> is pressed or held, the price will increase in 0.05 increments. If <down> is pressed or held, the price will decrease in 0.05 increments. After the desired price has been set, press <home> to save your setting and return to where the display flashes "ALL" followed by the new "ALL" price. You may now set a few, all, or different individual prices if desired.

## Section 3. Vender Programming

- Multi-pricing: If <up> or <down> is pressed when the display flashes “ALL” followed by the current majority price setting, the display will cycle through the individual price settings for each selection. The display will flash the selection number followed by the price for that selection. Example: If Selection 1 is set at 0.50, the display will flash “P 1” followed by “0.50”. Pressing <enter> while an individual selection is being displayed will cause the display to steadily show the vend price for that selection to allow a change to the price. Press <up> to increase the price value in 0.05 increments or <down> to lower it in 0.05 increments. After the desired price has been set, press <home> to save your setting and return to where the display flashes “P X” followed by the new selection price. From “PriC”, pressing <down> will take you to “tEst.” Pressing <up> will take you to “StoS.”



### Space-to-Sales Mode

This mode is a very important part of programming. It will determine what column will vend upon pressing a particular select button. You will use this mode to program column assignments by assigning a column (or columns) to each selection button that you desire to use. You may also decrease the number of vender selections. Example: The vender has a total of ten select buttons on the front panel. If you wish, you may program the controller to only use eight, seven, or six selections (or even less). This is done by assigning all additional columns to one of the popular selections being used. A benefit of doing this is you will be allowed to allocate the extra columns to a faster-selling flavor. Space-to-Sales Mode will come factory set for your type of vender. Upon entering the Space-to-Sales Mode two different types of settings are available:

- Factory Standard Space-to-Sales: There are eight factory preset settings from which to choose. These settings depend on how “C12” (Configuration 12) is set (for 12 or 10 columns).
- Custom Space-to-Sales: Allows you to custom-configure any column to any selection.

**OPERATION:** If <enter> is pressed when the display shows “StoS,” the controller will enter the Space-to-Sales Setting Mode. The control board will always enter at the current space-to-sales setting. If your vender is programmed for Custom Space-to-Sales, or if programmed with a Hand Held Computer, you will enter at “CStS.” If <up> or <down> is pressed at this point, you will be allowed to cycle through all space-to-sales settings.

- Factory Standard Space-to-Sales: Pressing <enter> at any Factory Standard (“Opt”) Setting will “lock in,” or reprogram, the control board for that particular space-to-sales setting. Upon doing this, the display will automatically start sequencing through each selection followed by all the columns that are assigned to each (see example below). After each selection has been shown, the display will return to “StoS.”

*Example: If after entering a Factory Standard Setting the display flashes “SL 1,” and then flashes “1,” then flashes “2,” selection one has been assigned to columns 1 and 2 only. This will occur for each selection.*

- Custom Space-to-Sales: Pressing <enter> at “CStS” will allow you to enter the Custom Space-to-Sales Mode. Upon entering this mode, the display will always start by flashing “SL 1” (Selection 1), followed by flashing each column number assigned to this selection. Example: The display flashes “SL 1,” then flashes “1,” and then flashes “2.” Selection 1 has columns 1 and 2 assigned to it only. Pressing <up> or <down> at this point allows you to cycle through selections 1 through 12, with each selection showing the columns assigned to it. If <enter> is pressed at a selection, the display will show “Co 1.” This stands for column 1 for that particular selection. Pressing <up> or <down> at this point will allow you to cycle through columns 1 through 10 for the selection entered. If any column is flashing, this means it is assigned to the selection. If a column is *not* flashing, then it is *not* assigned to the selection. Pressing <enter> will change a column’s flashing condition. This allows you to assign or un-assign columns. If no changes are made, pressing <home> will return you to the space-to-sales setting list at “CStS.” If a change to a selection is made, pressing <home> will return you to the selection level where the display flashes the selection number followed by the columns assigned to that selection. Follow this same procedure for all selections that you wish to program.

*Important Note: Anything done in this mode will override any previously assigned Factory Standard or Custom Settings.*

When completely finished in Custom Space-to-Sales Mode, pressing <home> will return you to “StoS” display. From “StoS” pressing <down> will take you to “PriC.” Pressing <up> will take you to “SdEP.”

## Section 3. Vender Programming

SdEP

### Set Vending Depth Mode

Since the vend motors on a MERLIN IV vender do not have cams or switches, electronically electronically the vending depth is extremely necessary. With older style Electro-Mechanical Venders, it was necessary to adjust the vend timing cam by either filling notches or rotating part of the cam to change the vending depth from triple or double to single depth. With the MERLIN IV vender, you have a choice of either single or double depth for each selection. It is necessary to program the correct depth for each selection to prevent multiple or slow vends. For instance, if your actual vending depth is two and you program this selection for single depth, it will double vend every time. (*Note: Depth is set by selection number, NOT by column number.*)

**OPERATION:** If <enter> is pressed when the display shows “SdEP”, the controller will enter the Set Vending Depth Setting Mode. The display will show “ALL.” From this point, two types of settings are available: the “ALL” depth setting enables you to set all depths the same (such as “ALL” of the price mode); the individual depth setting gives you the option to set all depths individually by selection.

- “ALL” setting: If <enter> is pressed when the display shows “ALL,” the controller will enter the Depth Setting Mode for all selections. The display will steadily show “ALL” and flash the current depth setting. Pressing <up> or <down> allows you to change the flashing depth setting between 1 or 2. Pressing <enter> will save changes and return you to where the display will show “ALL.” At this time, you will be able to cycle through each individual depth setting. Pressing <home> from this level will return you to the “SdEP” display.

*Note: If you have selection depth settings that are different, but a majority of the settings are the same, it is advised to set the majority setting from within the “ALL” setting first. You will then be able to program the few settings that are individually different. This will cut down on program time.*

- Individual Setting: If <up> or <down> is pressed when the display shows “ALL,” the controller will cycle through each individual setting showing the selection number and the current setting. If <enter> is pressed while the display is showing an individual depth setting, the current setting starts flashing. Pressing <up> or <down> allows you to change the flashing depth setting between 1 or 2. Pressing <home> locks in your setting and returns you to the individual level at the point where you entered it

(at the setting just changed). At this time, you will be able to cycle through each individual setting. Pressing <home> from the individual level returns you to the “SdEP” display. From “SdEP” pressing <down> will take you to “StoS”. Pressing <up> will take you to “Con”.

Con

### Configurations Mode

This mode is used to set vender options dealing with pricing, acceptance, payback, and a few other optional features. While in the Configurations Mode, the display will show the configuration followed by the current setting. If the display shows “C 1 0”, this means Configuration 1 is currently set to 0. In other words, the vender is set for single pricing. The configurations are as follows:

CONFIG.	SETTINGS
C1	0 = Single pricing 1 = Multiple pricing
C2*	0 = Hide optional menu items 1 = Show optional menu items
C4	0 = Display errors or “nonE” 1 = Display sales, cash values, and existing errors or “nonE”
C5	0 = No reset of individual counters 1 = Allow reset of individual counts upon reading and door switch actuation
C6	0 = Credit will be returned if proper change cannot be made 1 = Allow vend regardless of changer tube levels (change may not be paid)
C7	0 = Will allow bill acceptance regardless of payout availability 1 = Will only accept a bill if coin tubes have enough coins to cover the difference between the bill value and the maximum vend price
C8	0 = Escrow to vend (will act as a bill changer) 1 = Forced attempt (will not act as a bill changer)
C9	0 = Change is automatically returned to customer after a valid vend 1 = Will hold the customer’s change in escrow to allow a multiple purchase
C10	0 = Bill escrow disabled 1 = Bill escrow enabled

## Section 3. Vender Programming

C11	0 = All errors displayed 1 = Certain errors displayed
C12	0 = 12 column mode 1 = 10 column mode
C14**	0 = Energy Star® Tier 1 operation 1 = Energy Star® Tier 2 operation

**\*Note:** C2 - Versions 67100-7 and after.

**\*\*Note:** C14 - Versions 67100-11 and after. All venders with serial numbers beginning 200724 and higher should be set for Tier 2 operation. All others should be set for Tier 1.

**OPERATION:** If **<enter>** is pressed when the display shows “Con”, the controller will enter the Configurations Mode. The display will show Configuration 1 and its setting (as listed in the configurations’ description). If **<up>** or **<down>** is pressed at this point, the display will cycle through each configuration. Pressing **<enter>** while the display shows a configuration, allows the current configuration setting to start flashing. Pressing **<up>** or **<down>** while the current configuration setting is flashing, allows you to toggle the configuration setting between 0 and 1. If changes are made to a configuration, pressing **<enter>** will return you to the configuration list level and save any change. Follow the above process for all configurations which you wish to set. When done, pressing **<home>** will return you to the “Con” display. From “Con”, pressing **<down>** will take you to “SdEP”. Pressing **<up>** will take you to “rtn” if C2 is set to “0”, or to “ECO” if C2 is set to “1”.



### Return to Sales / Greeting Mode

This mode is used to exit the Service Menu and return to the Sales Mode, where the display flashes the greeting (ICE COLD or PEPSI COLA) along with any other display options.

**OPERATION:** If **<enter>** is pressed when the display shows “rtn”, the controller will revert to the Sales Mode and the greeting will be displayed. From “rtn”, pressing **<down>** will take you to “Con”. Pressing **<up>** will take you to “CASH”.

## Optional Menu Items



### Exact Change Value Mode

This mode controls the “Exact Change Only” light. If the machine cannot make change for the value (or lower) specified in this mode, the “Exact Change Only” light will be lit.

**Note:** 67100-X board and later versions

**OPERATION:** If **<enter>** is pressed when the display shows “ECO,” the controller will enter the Exact Change Value Mode. The display will show the exact change value. Pressing **<up>** or **<down>** allows you to adjust the value. Pressing **<home>** will save the currently displayed value and return you to the “ECO” display. From “ECO,” pressing **<down>** will take you to “Con.” Pressing **<up>** will take you to “CPO.”



### Coin Payout Mode

This mode allows you to payout coins from the coin mechanism’s tubes through the control board. This mode is mainly used because some types of coin mechanisms do not have payout buttons (switches) on them. This can also be used as a test to confirm the control board’s ability to payout coins (will payout the same as after a sale).

**OPERATION:** If **<enter>** is pressed when the display shows “CPO,” the controller will enter the coin payout mode and display the lowest coin value (0.05). Using **<up>** or **<down>** will allow the user to cycle through all coin values available for payout. If **<up>** or **<down>** is pressed and held at this point, a coin of the displayed value will be paid out. The word “PAY” will be displayed as coins are paid out. Coins will continue to payout as long as **<up>** or **<down>** is held. If **<home>** is pressed anytime during this operation, the controller will return to the “CPO” display. From “CPO”, pressing **<down>** will take you to “ECO”. Pressing **<up>** will take you to “tUFL”.

**Note:** If you are using the “tUFL,” you must use the Coin Payout Mode to pay out coins.

## Section 3. Vender Programming

### Coin Tube Fill Mode

This mode is used to keep inventory of the exact coin tube levels as each coin is inserted. During this mode, the LED display will register each coin as it is inserted (in no particular order) and report its value to the vender's control board. The control board will in turn remember the coin mechanism's coin tube levels and automatically deduct a coin each time a coin is paid out (through Coin Payout Mode or during a vend.). This mode can only be used if a Multi-Drop Bus (MDB) coin mechanism is in use.

**OPERATION:** If <enter> is pressed when this display shows "tUFL," the controller will enter the Coin Tube Fill Mode. The LED display will go blank allowing the deposit of all recognized values of coins through the coin insert or coin acceptor inlet chute. If <home> is pressed any time during this operation, the controller will return to the "tUFL" display. From "tUFL," pressing <down> will take you to "CPO." Pressing <up> will take you to "dSAL."

*Note: The use of the coin mechanism's manual coin payout buttons is discouraged to keep from corrupting the coin counts. As long as the sales greeting is scrolling, the manual buttons cannot be used.*

### Discounted Sale Counter Mode

This mode is very similar to the Sale Counter Mode. It allows you to manually extract the amount of product dispensed through your vender during the discounted sales periods (up to 99,999,999). The Sale Counter Mode consists of a non-resettable total count and individual count per selection which are resettable, depending upon the proper configuration setting (see Configurations). The counts can be displayed in up to two sets of four digits. Examples for both total and individual counters are:

Count Type	Actual Count	1 <sup>st</sup> Display	2 <sup>nd</sup> Display	3 <sup>rd</sup> Display
Total Sale Count	5,678,910	"SALE"	"567"	"8910"
Selection Sale Count	678,910	"SL [number]"	"67"	"8910"

**OPERATION:** If <enter> is pressed when the display shows "dSAL," the controller will enter the Discounted Sales Counter Mode. The display will flash "SALE" and the total amount of discounted sales made by the vender. This can be shown in two sets of four digits (as

shown in Example 1 above). Using <up> or <down> will cycle through individual discounted sales counts for each selection. The display will flash individual counts (as shown in Example 2 above). If <home> is pressed anytime during this operation, the controller will return to the "dSAL" display. From "dSAL," pressing <down> will take you to "tUFL." Pressing <up> will take you to "diFc."

**CLEARING INDIVIDUAL COUNTERS:** If the Configurations Mode is set to allow the individual counters to be reset, the individual counters will reset upon reading at least one of them and closing the vender's main door or actuating the vender's door switch.

### Differential Cash Discounted Counter Mode

This mode is comparable to the Cash Mode. It allows you to monitor the difference between discounted prices and regular prices. The Differential Cash Discounted Counter Mode is a non-resettable total count. If product is sold for less than the vend price, the counts will be preceded by a negative symbol (-). If product is sold for greater than the vend price, the counts will be shown normally. Examples for both are:

Count Type	Actual Count	1 <sup>st</sup> Display	2 <sup>nd</sup> Display	3 <sup>rd</sup> Display
Differential Cash Count (Negative)	-\$789.10	"CASH"	"-7"	"89.10"
Differential Cash Count (Positive)	\$789.10	"CASH"	"67"	"89.10"

**OPERATION:** If <enter> is pressed when the display shows "diFc," the controller will enter the Differential Cash Discounted Counter Mode. The display will flash "CASH" and the total difference between regular vend prices and discounted prices (as shown in Example 1 above). Pressing <home> anytime during this operation will allow the controller to return to the "diFc" display. From "diFc," pressing <down> will take you to "dSAL." Pressing <up> will take you to "SdiS."

**CLEARING INDIVIDUAL COUNTERS:** This is a non-resettable counter.

## Section 3. Vender Programming

Sd 5

### Set Discount Pricing Mode

This mode is used to set discount prices for each selection. This mode works in conjunction with the built-in timer in the Time and Timer Settings Mode (“tinE”). Before entering “tinE,” you must set the selections to “1” in Set Timer-Controlled Selections Mode (“StCL”). After “StCL,” you may set the discounted price for each desired selection. Then, set the time you wish the discounted selection to be activated by using the “dScn” settings in “tinE” under the day function.

**OPERATION:** If <enter> is pressed when the display shows “SdiS,” the controller will enter the Discount Price Setting Mode. The display will flash “ALL” (for all selections) and the last discount price value that “ALL” was set at. This is referred to as the selection level. If <enter> is pressed at this point, the display will steadily show the discount value for all selections. Press <up> to increase the discount price value in 0.05 increments or <down> to lower it in 0.05 increments. If <home> is pressed after adjusting the price, your new discount price will be saved and the display will return to the selection level. You may now set a few, all, or different individual discount prices if desired. If <up> or <down> is pressed when the display flashes “ALL” (for all selections) then flashes the last discount price value that “ALL” was set at, the display will cycle through the individual discount price settings for each selection. The display will show the selection number followed by the discount price for that selection. Example: If selection one is set at 0.50, the display will flash “P 1,” followed by “0.50.” Pressing <enter> while an individual selection is being displayed will cause the display to steadily show the discounted vend price for that selection to allow a change to it. Press <up> to increase the discount price value in the same fashion as above or <down> to lower it. Pressing <home> after adjusting a price will save that price and return you to the selection level. Pressing <home> while at the selection level will return you to the “SdiS” display. From “SdiS,” pressing <down> will take you to “diFc.” Pressing <up> will take you to “StCL.”

StCL

### Set Timer Controlled Selections Mode

This mode is used to choose the selections to turn off using the built-in timer or with the optional key switch kit. This mode must be set to enable one or all of the selections for the timer or the key switch to operate. The timer or key switch will control any selections set to “1.” Selections set to “0” will function normally.

**OPERATION:** If <enter> is pressed when the display shows “StCL,” the control board will enter the Set Timer Controlled Selections Mode at the selection level and the display will show “ALL.” From this point, two types of settings are possible:

- “ALL” setting: If <enter> is pressed when the display shows “ALL” and the current setting, the control board will enter the “ALL” setting mode. The display will steadily show “ALL” and flash the current “StCL” setting. Pressing <up> or <down> allows you to change the flashing setting between 0 and 1. Pressing <enter> saves any change and returns you to the selection level where the display steadily shows “StCL” and the new setting. At this time you will be able to cycle through each selection to set individual settings. If completely done, pressing <home> from the selection level (display shows “ALL” and current setting) will return you to the “StCL” display.
- Individual setting: If <up> or <down> is pressed when the display shows “ALL” and the current setting, the controller will cycle through each selection showing the selection number and the current setting for that selection. (Example: The display may show “t 3 1,” meaning that for selection 3, the timer is turned on.) If <enter> is pressed while the display is showing an individual selection timer setting, the current setting for that selection will start flashing. Pressing <up> or <down> allows you to change the flashing timer setting between “0” and “1.” Pressing <enter> saves any change and returns you to the selection level. At this time you will be able to cycle through each selection to set other individual timer-controlled selection settings. Pressing <home> from the selection level will return you to the “StCL” display. From “StCL,” pressing <down> will take you to “SdiS.” Pressing <up> will take you to “tinE.”

**Notes:** When pressing a selection in the StCL Mode:

1. Version 67100-3 and after, the LED will display “No Sale till XXXX” (where the X’s represent the time set for the timer).
2. Version 67100-2 and prior, the LED will show the greeting and “Sold Out”.

## Section 3. Vender Programming



### Time and Timer Settings Mode

This mode is used mainly to turn selections, lighting, and/or refrigeration off and back on during predetermined times of the day and days of the week. In the “tinE” Mode, you must set the current year, date, hour and day of the week for the timer to operate. The “tinE” Mode is also used to set each “on” and “off” time in which the timer will operate. Within the “tinE” Mode, there are several different functions listed below with a meaning and example for each.

FUNCTION	PROGRAM MEANING	DISPLAY EXAMPLE (after entering mode)
YEar	Current year	“2007”
datE	Current month / day	“06.10” (June 10)
hour	Current hour / min.	“13.30” (1:30 pm) 24-hour time
SEtd	Set day of the week	“SUN”
StOP	Disable clock*	“CLOC” / “StOP”
daY	Timer on / off days and times	“ALL”
dSt	Display time on LED	“dSt” with setting flashing
dLt	Daylight saving time	“dLt” with setting flashing

*\* This feature is used to conserve the control board’s built-in battery if the vender is in storage for long periods of time. The lithium battery shelf life is about three years with the clock turned on and ten years with it off.*

**OPERATION:** If <enter> is pressed when the display shows “tinE,” the controller will enter the Time and Timer Settings Mode and the display will show “YEar.” Pressing <up> or <down> allows you to cycle through each “tinE” function. Pressing <home> while the display is showing any of the earlier listed “tinE” functions will return you to the “tinE” display. When completely finished with all “tinE” functions, pressing <home> from the “tinE” functions menu returns you to the code level where the display shows “tinE”. Pressing <down> will take you to “StCL.” Pressing <up> will take you to “FriG.”

- Year function (“YEar”): If <enter> is pressed when the display shows “YEar,” the controller will enter the year setting function and the display will show the year, with the first two numbers of the year flashing (example: 20.07). Pressing <up> or <down> allows

you to change the first two digits of the year. If <enter> is pressed at this point, the first two numbers of the year lock in and the second set of digits start to flash (example: 20.07). Pressing <up> or <down> allows you to change the second two digits of the year. Pressing <home> saves any change and returns you to the beginning of the year function where the display shows “YEar.” From “YEar,” pressing <down> will take you to “dLt.” Pressing <up> will take you to “dAtE.”

- Date function (“dAtE”): If <enter> is pressed when the display shows “dAtE,” the controller will enter the date setting function and the display will show the current date, with the first two numbers of the date flashing to indicate the month (example: 06.10). Pressing <up> or <down> allows you to change the first two numbers of the date. If <enter> is pressed from this point, the first two numbers of the date lock in and the second set of two digits will start flashing to indicate the day (example: 06.10). Pressing <up> or <down> allows you to change the second two numbers of the date. Pressing <home> anytime during this process saves any change and returns you to the beginning of the date function where the display shows “dAtE.” From “dAtE,” pressing <down> will take you to “YEar.” Pressing <up> will take you to “hour.”
- Hour function (“hour”): If <enter> is pressed when the display shows “hour,” the controller will enter the hour setting function and the display will show the current hour in 24-hour time with the first two numbers of the hour flashing (example: 13.30). Pressing <up> or <down> allows you to change the hour. If <enter> is pressed from this point, the first two numbers of the hour lock in and the second set of two digits will start flashing to indicate the minutes (example: 13.30). Pressing <up> or <down> allows you to change the second two numbers of the hour. Pressing <home> after making a change will return you to the beginning of the hour function where the display shows “hour.” From “hour,” pressing <down> will take you to “dAtE.” Pressing <up> will take you to “SEtd.”
- Set day function (“SEtd”): If <enter> is pressed when the display shows “SEtd,” the controller will enter this mode displaying a day of the week. Pressing <up> or <down> allows you to change the day of the week. When the desired day is selected, press <home> to select and bring you to “SEtd.” From “SEtd,” pressing <down> will take you to “hour.” Pressing <up> will take you to “StOP.”

## Section 3. Vender Programming

- Stop clock function (“StOP”): If <enter> is pressed when the display shows “StOP,” the controller will enter the stop clock function and the display will flash “CLOC” and “StOP.” Pressing <enter> will turn off the clock to preserve the controller’s built-in battery. The display will flash “Off” and automatically exit back to the display of “StOP.” Pressing <home> anytime during this process will return you to the beginning of the stop clock function where the display shows “StOP.” From the “StOP” display, pressing <down> will take you to “hour.” Pressing <up> will take you to “dAY.”
- Day function (“dAY”): If <enter> is pressed when the display shows “dAY,” the controller will enter the function to allow you to set the timer on / off times for each day of the week. The display will show “ALL.” From this point you have two different options: the “ALL” timer setting will enable you to set all days the same in which the timer operates (similar to “ALL” in the price mode), and individual-day timer settings will give you the option to set all the timer operations differently for each day. Pressing <up> or <down> allows you to cycle from “ALL” to each day of the week. If <enter> is pressed, either at “ALL” or a week day, the controller will enter into that particular day. The display will show “SC-1,” then “On,” and then the current first “Off” time for selections as listed below. From here on, this will be referred to as the Timer Setting Mode Viewing-Only Level. If <up> or <down> is pressed at the Timer Setting Mode Viewing Only Level, the display will cycle to all other available timer setting modes:

SETTING MODE	PROGRAM MEANING
“SC-1”... “On”	1 <sup>st</sup> OFF time for selections
“SC-1”... “Off”	1 <sup>st</sup> ON time for selections
“SC-2”... “On”	2 <sup>nd</sup> OFF time for selections
“SC-2”... “Off”	2 <sup>nd</sup> ON time for selections
“SC-3”... “On”	3 <sup>rd</sup> OFF time for selections
“SC-3” ... “Off”	3 <sup>rd</sup> ON time for selections
“dScn”... “On”	ON time for discounted selections
“dScn”... “Off”	OFF time for discounted selections
“FriG”... “On”*	OFF time for refrigeration system
“FriG”... “Off”*	ON time for refrigeration system
“Lt-1”... “On”	1 <sup>st</sup> OFF time for illumination (ballast lighting)
“Lt-1”... “Off”	1 <sup>st</sup> ON time for illumination (ballast lighting)
“Lt-2”... “On”	2 <sup>nd</sup> OFF time for illumination (ballast lighting)
“Lt-2”... “Off”	2 <sup>nd</sup> ON time for illumination (ballast lighting)

“Lt-3”... “On”	3 <sup>rd</sup> OFF time for illumination (ballast lighting)
“Lt-3” ... “Off”	3 <sup>rd</sup> ON time for illumination (ballast lighting)

\* - 67100-8 and lower only. See Refrigeration Mode for newer controllers.

To set “On” and “Off” times for the timer, you must press <enter> upon reaching the desired timer setting mode. After doing this, the controller will enter into that particular timer setting mode. The display will show the current setting with the hour flashing. This indicates that the hour can now be changed. Pressing <up> or <down> allows you to change the hour of this particular setting. Pressing <enter> will lock in the hour setting and start the minutes flashing (which will indicate to you the minutes can now be changed). Pressing <up> or <down> allows you to change the minutes of this setting. Pressing <home> anytime during this process will lock in your changes and bring you back to where the display shows the timer setting mode and the time set for that mode (Timer Setting Mode Viewing Only Level).

At this point, <up> or <down> allows you to access all timer setting modes listed earlier. From this Timer Setting Mode Viewing Only Level, pressing <home> again will return you to the day of the week level. Press <home> once more to return to the display of “dAY.” From “dAY,” pressing <down> will take you to “StOP.” Pressing <up> will take you to “dSt.”

*Note: If you are setting certain selections to go off and come back on at a programmed time, you must first enter “SC-1 On” to set the first off time for selections. When done programming the first off time, you must then program the first return on time for the selections by entering into “SC-1 Off” and programming your return on time. For the timer to be able to control the selections, you must set the selections to be controlled in the “StCL” mode of the password-protected menu.*

- Display time function (“dSt”): If <enter> is pressed at this display, the controller will enter the display time setting mode and the display will show “dSt” while flashing the current setting. Pressing <up> or <down> allows you to change the flashing setting back and forth between “0” and “1.” If set to “1,” the time of day will be displayed on the LED during the greeting. If set to “0,” the time will not be displayed during the greeting. Pressing <home> at any time during the process will save changes and return

## Section 3. Vender Programming

you to the “dSt” display. From this point, pressing <down> will take you to “dAY.” Pressing <up> will take you back to “dLt.”

- Daylight Saving Time function (“dLt”): This option allows for the automatic adjustment of Daylight Saving Time. If enabled, the time will automatically be adjusted forward one hour at 2:00 a.m. (2:02 a.m. at the latest) on the second Sunday in March and similarly adjusted back one hour on the first Sunday in November. If <enter> is pressed at this display, the control board will enter the Daylight Saving Time enable / disable mode. The display will show “dLt” and flash the current setting. Pressing <up> or <down> allows you to change the flashing setting back and forth between “0” and “1.” If set to “1,” Daylight Saving Time will be enabled. If set to “0,” Daylight Saving Time will be disabled. Pressing <enter> anytime during the process will save any change and returns you to the start of the Daylight Saving Time function where the display will show “dLt.” From this point, pressing <down> will take you to “dSt.” Pressing <home> will take you back to “tinE.”

*Note: This is important if you are using the timer function set to “1.”*

### Refrigeration Parameters Mode

This mode is used to control the environmental aspects of the vender. It controls the refrigeration system by allowing you to program the cut-in and cut-out temperatures of the refrigeration unit. The “FriG” Mode also allows you to show the current inside cabinet temperature on the LED (during the greeting). The temperatures shown on the LED during the greeting and programming can be changed from Fahrenheit to Celsius. The “FriG” Mode has a relay mode allowing you to test any controlling relays in the vender (evaporation fan, refrigeration, illumination, and heater). Within the “FriG” Mode, there are several different functions, as listed below.

#### **67100-9 AND HIGHER:**

If <enter> is pressed at the “FriG” prompt the controller will enter the refrigeration control mode. Using <up> or <down>, you can rotate through the various refrigeration control settings (“Enb,” “Strt,” “StOP,” “dEG,” “SEtP,” “Stor,” “dSP,” and “rELY”). If <exit> is pressed, the controller will return to the “FriG” prompt. Press <up> to proceed to the next prompt, “PAS.”

- **Enb**  
Upon first entry into “FriG,” the controller will display “EnbX.” If <enter> is pressed at “EnbX,” “X” will begin to flash, indicating that it can be edited. If X = 1, the energy conservation control will be enabled. This means the cabinet temperature will be allowed to rise to the programmed storage level during programmed time blocks. If X = 0, the energy conservation mode will be disabled, and the machine will function as normal. Pressing <up> or <down> will allow you to toggle “X” between 1 (enabled) and 0 (disabled). Pressing <enter> will save the displayed setting and return you to the non-editable “Enb” prompt. Use <up> to proceed to the next prompt, “Strt.”
- **Strt**  
If <enter> is pressed at the “Strt” prompt, the controller will enter the start energy conservation time setting routine. Upon entry into this routine, the display will show “dAY.” Pressing <exit> at this point will return to the “Strt” prompt without saving any changes.

If <enter> is pressed at the “dAY” prompt, the controller will enter the day of the week setting routine. Upon entry into this routine, the display will show “ALL,” representing every day of the week. Pressing <up> or <down> will rotate through “Sun,” “Mon,” “tuE,” “Wed,” “thu,” “Fri,” “Sat,” or “ALL.” Pressing <enter> at any of these prompts will cause the controller to enter the hour:minute time setting routine for that day. The display will show the current four-digit hour and minute setting, in 24-hour format. The hour setting will be flashing to indicate that it can be modified. Pressing <up> or <down> will increase or decrease the hour. Pressing <enter> will stop the hour from flashing and cause the minutes to flash, indicating that they can be modified. At this point pressing <up> or <down> will increase or decrease the minutes value. Pressing <exit> will save the hour and minute setting for the corresponding day value and will return to the prompt for that day. Pressing <exit> again will return you to the “dAY” prompt. Pressing <exit> one more time will return you to the “Strt” prompt.

- **StoP**  
If <enter> is pressed at the “StoP” prompt, the controller will enter the stop energy conservation time setting routine. Upon entry into this routine, the display will show “dAY.” Pressing <exit> at this point will return to the “StoP” prompt without saving any changes.

If <enter> is pressed at the “dAY” prompt, the controller will enter the day of the week setting routine. Upon entry into this routine, the display will show “ALL,” representing every day of the week. Pressing <up> or <down> will rotate through

## Section 3. Vender Programming

“Sun,” “Mon,” “tuE,” “Wed,” “thu,” “Fri,” “Sat,” or “ALL.” Pressing <enter> at any of these prompts will cause the controller to enter the hour:minute time setting routine for that day. The display will show the current four-digit hour and minute setting, in 24-hour format. The hour setting will be flashing to indicate that it can be modified. Pressing <up> or <down> will increase or decrease the hour. Pressing <enter> will stop the hour from blinking and cause the minutes to flash, indicating that they can be modified. At this point pressing <up> or <down> will increase or decrease the minutes value. Pressing <exit> will save the hour and minute setting for the corresponding day value and will return to the prompt for that day. Pressing <exit> again will return you to the “dAY” prompt. Pressing <exit> one more time will return you to the “StoP” prompt.

- **dEG**

If <enter> is pressed at the “dEG “ prompt, the controller will display “dEGX,” where X will be flashing: ‘F’ if the controller is currently in Fahrenheit mode, or ‘C’ if the controller is currently in Celsius mode. Pressing <up> or <down> will toggle the X digit between ‘F’ and ‘C’. Pressing <exit> at this point will save the displayed temperature mode and return you to the “dEG “ prompt.

- **SetP**

If <enter> is pressed at the “SetP “ prompt, the controller will display the current set point temperature setting “xx F” or xxC,” depending on the degree (“dEG”) mode setting. The cold set point default is 35°F (2°C). Pressing <up> or <down> will adjust the temperature value by 1°F (0.5°C). The set point temperature can be adjusted from 25°F through 45°F. Pressing <exit> at this point will save the displayed temperature and return you to “SetP”.

- **Stor**

If <enter> is pressed at the “Stor” prompt, the controller will display the current storage (for energy conservation mode) temperature setting “xx F” or “xxC,” depending on the degree (“dEG”) mode setting. The default storage temperature is 60°F. Pressing <up> or <down> will adjust the temperature value by 1° (0.5°C). The set point temperature can be adjusted from 45°F through 75°F. Pressing <exit> at this point will save the displayed temperature and return you to “Stor”.

- **dSP**

If <enter> is pressed at the “dSP” prompt, the controller will display “dSPX,” where X will be ‘0’ if

the controller is not currently displaying the cabinet temperature, or ‘1’ if the controller is currently displaying the cabinet temperature after the POS message. Pressing <up> or <down> will toggle “X” between 0 and 1. Pressing <exit> at this point will save the currently displayed setting and return you to the “dSP” prompt.

- **rELY**

If <enter> is pressed at the “rELY” prompt, the controller will enter the relay test mode by displaying “Fan.” If the <exit> key is pressed in this mode, the user will return to the “rELY” prompt. Using <up> or <down> will allow the operator to toggle between the following modes:

“Fan “	Evaporator fan relay
“LitE”	Machine light control relay
“Htr “	Heater Kit relay
“CnPr”	Compressor relay

If <enter> is pressed at any of these prompts, the controller will alternately flash the prompt with the word “OFF,” if that relay is currently off; or the word “ON,” if that relay is currently on. Pressing <up> or <down> will toggle the alternate display word between “OFF” and “ON.” Pressing <enter> at this point will override that relay’s current status until either the status is changed or until the “rELY” mode is exited completely. The display will return to the relay test mode. When the “rELY” mode is exited, all relays will return to the state they were in prior to entering the “rELY” mode.

*NOTE: In this feature, the user has the ability to continuously turn the compressor on and off. Be aware that quickly re-starting the compressor can result in serious damage to the compressor.*

- **dFSt (67100-11 and after)**

If <enter> is pressed at the “dFSt” prompt, the controller will enter the defrost interval setting mode. “dFSt” works in conjunction with Energy Star® Tier 2. The default defrost interval is 3 hours. This setting is used to determine how often the machine will go into defrost mode. If <enter> is pressed at the “dFSt” prompt, the controller will display the current defrost interval setting, “NN,” where the N’s represent the interval setting in hours. Using <up> or <down> will increase or decrease the interval setting in hours, from 3 to 24. Pressing <exit> at this point will save the currently displayed setting and return you to the “dFSt” prompt.

# Section 3. Vender Programming

## 67100-8 AND BEFORE:

*Note: The “FriG” Mode is only applicable in venders using Electronic Refrigeration Mode. However, if the “FriG” setting is set to “1”, without the use of electronic control, the display will show unnecessary “FriG” errors.*

**OPERATION:** If <enter> is pressed when the display shows “FriG”, the controller will enter the Refrigeration Mode, and the display will show “Cuti.” Pressing <up> or <down> allows you to cycle through all the “FriG” functions. When completely finished with all programming in the “FriG” Mode, pressing <exit> while the display is showing any of the earlier listed “FriG” functions will return you to the “FriG” display. From “FriG,” pressing <down> will take you to “tinE.” Pressing <up> will take you to “PAS.”

- Cut-in function (“Cuti”): If <enter> is pressed when the display shows “Cuti,” the controller will enter the cut-in setting function and the display will show the current cut-in temperature setting (factory setting: 41°F). Pressing <up> or <down> allows you to change the cut-in setting. The setting can be adjusted from 39°F to 45°F (4°C to 7°C). Pressing <exit> at any time during this process will save any change and return you to the beginning of the cut-in function where the display shows “Cuti.” From “Cuti,” pressing <down> will take you to “rELY.” Pressing <up> will take you to “Cuto.”
- Cut-out function (“Cuto”): If <enter> is pressed when the display shows “Cuto,” the controller will enter the cut-out setting function. The display will show the current cut-out temperature setting (factory setting: 29°F). Pressing <up> or <down> will allow you to change the cut-out setting. The setting can be adjusted from 24°F to 34°F (-4°C to 1°C). Pressing <exit> at any time during this process will save any change and return you to the beginning of the cut-out function where the display shows “Cuto.” From “Cuto,” pressing <down> will take you to “Cuti.” Pressing <up> will take you to “dEG.”
- Degree system function (“dEG”): If <enter> is pressed when the display shows “dEG,” the controller will enter the degree system function. The display will show “dEG” and flash the current degree system setting. Pressing <up> or <down> will allow you to change the current setting. Program to “F” for Fahrenheit (factory setting) or “C” for Celsius. Pressing <exit> at any time during this process will save any change and return you to the beginning of the degree system function where the display shows

“dEG.” From “dEG,” pressing <down> will take you to “Cuto.” Pressing <up> will take you to “dSP.”

- Display temperature function (“dSP”): If <enter> is pressed when the display shows “dSP,” the controller will enter the display temperature function. The display will show “dSP” and flash the current setting. Pressing <up> or <down> allows you to change the current setting. Program to “1” to show the temperature on the LED display during the sales greeting or “0” to not show the temperature during the greeting. Pressing <exit> at any time during this process will save any change and return you to the beginning of the display temperature function where the display shows “dSP.” From “dSP,” pressing <down> will take you to “dEG.” Pressing <up> will take you to “FrG.”
- Refrigeration master control function (“FrG”): If <enter> is pressed when the display shows “FrG,” the controller will enter the refrigeration master control function. The display will show “FrG” and flash the current setting. Pressing <up> or <down> allows you to change the current setting. Program to “1” for the refrigeration unit to operate normally or “0” to disable the unit. Pressing <exit> at any time during this process will save any change and return you to the beginning of the refrigeration master control function where the display shows “FrG.” From “FrG,” pressing <down> will take you to “dSP.” Pressing <up> will take you to “rELY.”
- Relay test function (“rELY”): If <enter> is pressed when the display shows “rELY,” the controller will enter the relay test function to allow you to test the various vender relays. The display will show “Fan” (which is the test mode for the optional evaporator fan motor relay). Pressing <up> or <down> allows you to cycle through each relay test mode available.

RELAY TEST MODE MENU	MEANING
Fan	Evaporator fan relay test (requires optional kit)
Htr	Heater relay test (requires optional kit)
LitE	Illumination relay test (requires optional kit)
CnPr	Compressor relay test

## Section 3. Vender Programming

If **<enter>** is pressed at any of the four relay test modes, the display will flash the name of the relay and then flash “Off.” If the relay is currently off and you wish to enable it, press **<enter>**. If not, pressing either **<up>** or **<down>** allows the display to flash the name of the relay and then flash “Off.” If the relay is currently off and you wish to test the circuit by turning it on, press **<enter>** here. If the circuit tested does not work, you will have five minutes in test mode to check voltage. Pressing **<exit>** from within any relay test mode will allow you to return to the relay test mode menu (where the display will show the name of the relay menu you were just in). Pressing **<exit>** from a point on the relay test mode menu returns you to the beginning of the relay mode (where the display shows “rELY”).

### External Menu Password Setting Mode

With the MERLIN IV vender, you have the capability to access both total historical and individual selection can counts externally. You are also able to read vender errors externally (errors cannot be cleared externally). The “PAS” Mode gives you the option to change the external password to any of your select buttons in a four-digit combination, or you may decide it best to use the factory setting of **1 - 3 - 2 - 4** (*earlier software versions used 4 - 2 - 3 - 1*). If you do decide to set your own password and happen to forget it, just access this menu and the current password will be displayed.

#### HELPFUL HINTS

1. Password numbers range from 0 to 9.
2. If your vender only has seven selections, you cannot use 8, 9, or 0 in your password, or you will not be able to enter the password.
3. To disable the external password, set one of the four digits to “0” or a selection that is not available (as described in Hint #2).

**OPERATION:** If **<enter>** is pressed when the display shows “PAS,” the controller will enter the External Menu Password Setting Mode. The display will show the current external password with the first number of the four (to extreme left of display) flashing. Pressing **<up>** or **<down>** allows you to change the flashing digit. If **<enter>** is pressed, the second number from the left will start flashing. By doing this, you lock in any changes

made to the first digit and you are now able to change the second digit. Follow the same process for every digit. If the fourth digit is flashing and **<enter>** is pressed, you will return to “PAS.” Pressing **<home>** at any time during this process locks in your setting and returns you to the “PAS” display. From “PAS,” pressing **<down>** will take you to “FrIG.” Pressing **<up>** will take you to “LAnG.”

### Language Setting Mode

The MERLIN IV vender gives you the opportunity to set vending messages, such as “ICE COLD” and “SOLD OUT,” in English, Hebrew, French, German, or Spanish.

**OPERATION:** If **<enter>** is pressed when the display shows “LAnG,” the controller will enter the Language Setting Mode. The display will show the current language being used. Pressing **<up>** or **<down>** allows you to change the language to one of the following:

<b>EnGL</b>	English
<b>HEbr</b>	Hebrew
<b>FrEn</b>	French
<b>GEr</b>	German
<b>SPAn</b>	Spanish

Pressing **<home>** at any time during this process saves any change and returns you to the “LAnG” display. From “LAnG,” pressing **<down>** will take you to “PAS.” Pressing **<up>** will take you to “rtn.”

### Return to Sales

This mode is used to exit the Service Menu and return to the Sales Mode, where the display flashes the greeting (“ICE COLD,” etc.) along with any other display options.

**OPERATION:** If **<enter>** is pressed when the display shows “rtn,” the controller will revert to the Sales Mode and the greeting will be displayed. From “rtn,” pressing **<down>** will take you to “LAnG.” Pressing **<up>** will take you to “CASH.”

# Section 3. Vender Programming

## External Menu

By entering the correct four-digit password when the vender is in stand-by condition (display is showing the greeting, a credit is not established, and the vender is not set for free vend), you will access the External Menu. This menu consists of three menu items previously discussed in the Internal Menu. The External Menu is designed to give you access to a few features, such as total and individual (per selection) vend counts, vender error diagnostics, and a clearing feature for individual vend counts. This menu may come in handy for a location manager who does not have access to the inside of the vender but wishes to report problems and get vend counts. Programming CANNOT be done through this menu!

*Note: After five minutes without activity, if money is inserted or if the coin return lever is actuated, the control board will revert to the Sales Mode (the LED will show the greeting).*



### Sale Counter Mode

This mode is very similar to the Cash Counter Mode. The Sale Counter Mode allows you to manually extract the amount of product vended from your vender (up to 99,999,999 vends). The Sale Counter Mode consists of a non-resettable total count and individual selection counts. These are resettable depending upon the proper configuration setting (see Configurations). The counts will be preceded by the count type and can be displayed in one or two sets of four digits. Examples for both types of Sale Counters are as follows:

Count Type	Actual Count	1 <sup>st</sup> Display	2 <sup>nd</sup> Display	3 <sup>rd</sup> Display
Total Sale Count	5,678,910	"SALE"	"567"	"8910"
Selection Sale Count	678,910	"SL [number]"	"67"	"8910"

**OPERATION:** If <enter> is pressed when the display shows "SALE," the control board will enter the Sale Counter Mode. The display will flash "SALE" and the total amount of sales made by the vender, possibly in two sets of four digits (see Example 1 above). Using <up> or <down> will cycle through individual selection sale counts. The display will flash individual selection counts (see Example 2 above). If <home> is pressed at any time during this operation, the controller will return to the "SALE" display. From "SALE," pressing <down> will take you to "Error." Pressing <up> will take you to "rtn" (if present).



### Return to Sales

This mode is used to exit the External Menu and return to the Sales Mode where the display flashes the greeting ("ICE COLD," etc.) along with any other display options.

**OPERATION:** If <enter> is pressed when the display shows "rtn," the controller will revert to the Sales Mode and the greeting will be displayed. From "rtn," pressing <down> will take you to "Sale." Pressing <up> will take you to "Error."



### Errors Mode

This mode was designed to help diagnose vender problems. Upon entering this mode, the display will flash any possible error (for a list, refer to Section 6, Vender Maintenance: Error Codes). If there are no errors, the display will momentarily flash "none" and revert to "Error" on the External Menu. Errors cannot be cleared from this External Errors Mode. They have to be cleared from the Internal Menu.

**OPERATION:** If <enter> is pressed when the display shows "Error," the controller will enter into the External Errors Mode. At this point, the display will show any and all current vender errors followed by the descriptions for each. If no errors exist, "none" will appear on the display. If <home> is pressed at any time during this operation, the controller will return to the "Error" display. From "Error," pressing <down> will take you to "rtn."

**CLEARING ERRORS:** To clear an error, you must access the "Error" Mode from within the Password Protected Menu.

## Section 4. Vend Cycle

---

# Vend Cycle

## Stand-By Condition

In a stand-by condition, the vender will show the greeting and possibly the vend price (if set for a single price or if all prices are set to same) and a choice of other optional features on the LED display. If a select button is pressed prior to reaching the vend price (establishing a credit), the display will show the vend price for that selection. This will indicate to the customer more money is needed for that particular selection.

## Establishing Credit

As coins are inserted into the coin mechanism, a corresponding credit count will appear on the display. The coin mechanism will continue to accept coins until the highest vend price has been achieved. All coins in excess of the vend price will be returned to the coin cup. Once the vend price has been achieved, the control board will set up a credit enabling a vend to be made for any selection equal to or less than the established credit.

## Valid Selection

The vender's control board constantly sends a logic level signal to the common position of each select switch. When a selection is made, the selection switch closes. This allows the low voltage signal to travel from the switches common position through the switch and out the normally open position of that switch to the select switch's harness connection on the control board.

## Vend Sequence

At this time (if there has not been a previous sold out), the control board distributes 24 volts DC through the door and cabinet wiring harnesses and directly to the coil of the chosen vend motor. Simultaneously the display will scroll. This is an indication to the customer a vend is in progress and to please wait. As the vend motor receives power, it will turn the rotor in an attempt to vend a can.

## Product Delivery

As the can or bottle drops onto the product delivery chute, the vibration from the impact will allow the delivery sensor to send a low voltage signal to the vender's control board. This indicates that a product has been vended. After the control board receives the sensor's signal, it will take into account how the vender is programmed (set depth) and will act accordingly. If the first can has just vended, the control board will kill all power to the vend motor at the exact same time that an impact is registered (this avoids a multiple vend of the next product to the rear of the cabinet). As the next can vends, the control board will cycle the vend motor to pick up another load of product. This allows a

quick vend, less than three seconds, for the next customer.

***Note:** The control board will go through a learning process known as the Learning Mode. It will be reset either on power down/up or a door opening/closing. This allows the vender's controller to decide which is the front or rear product. The Learning Mode acts in conjunction with the depth setting to allow for an automatic reload after the rear can has vended. How it works: The controller will notice the first "long-timed out" vend cycle during the learning process. From this, the controller will know the very next vend will be the front product.*

## Column Sequencing

If a selection has multiple columns assigned to it, the same column is vended each time the selection button is pressed until the number of times vended is equal to the depth of the column. Then, that selection proceeds to the next column assigned. This is to allow the columns to vend evenly.

## Sold-Out

Upon selection, the display will cycle to show the vend progress. After ten to twelve seconds (if a drop of product is not detected), the display will show "sold-out." A sold out may be due to:

1. The column attempted is jammed, therefore product does not drop,
2. The column attempted is genuinely sold out, or
3. The sensor is out of adjustment and does not detect the product drop.
4. If any or all selection, doesn't have a column assigned, it will read "Sold Out."

The digital display will indicate "sold out" and flash the sold out lamp. This signals to the customer to make another selection or push the coin return lever for a full refund. If set for forced purchase, the customer must make an initial selection. If the initial selection is sold out, the customer will be allowed a full refund or an alternate selection. If the vender is totally sold out of a product, illumination of the "sold out" lamp and the "sold out" message on the digital display will be continuous. No money will be accepted into the vender in a total sold out condition.

## Resetting Sold Out Selections

A sold out condition is only cleared by the vender's door switch by opening the vender's main door. If a sold out condition is not cleared, the controller will not attempt to vend from that selection. The display will not cycle to indicate a vend is in progress. It will automatically show "sold-out" upon pressing the select button (either before or after reaching a vend price).

## Section 5. Vender Maintenance

# Vender Maintenance

## What to Clean



**WARNING:** Electrical and electronic components should NEVER be subjected to water. Do not use hoses or pressure washers to clean the interior of the vender.

**Cabinet and Vend Mechanism:** Steam clean as required. *Never* use petroleum cleaners.

**Condenser and Evaporator Coils:** For efficient operation, the condenser and evaporator coils must be kept clear of any dirt or foreign materials. Clean dirt and debris from the condenser and evaporator coils with a small light-bristled brush, vacuum cleaner, or compressed air. This will help to ensure an extended unit life.

**Control Board:** The vender's control board should always be enclosed by its cover to protect it. Routine cleaning is not necessary but, if desired, the controller's area may be blown out with compressed air.

## What to Lubricate

**Inner Door Gasket:** The door gasket comes from the factory pre-lubricated but should be lubricated periodically with a silicone-based grease. Apply to the vertical piece of gasket on the hinged side of the inner door which touches the vender's main door. This will help prevent any peel-back of the gasket which can cause air leaks into the sealed cabinet, resulting in freeze-ups.

**Latch Strike Nut:** The latch strike nut should be lubricated as needed.

**Refrigeration Unit:** The refrigeration unit is a sealed system that does not require any lubrication. Also, the condenser and evaporator fan motors do not require any lubrication.

**Anti-friction Sheets:** The anti-friction sheets should be lubricated with a thin layer of food-grade silicone. The sheets should be kept clean and free of debris, and they should not be peeling.

## Preventive Maintenance

**Vender Leveling:** Make sure that the vender is level when placed on site. If the vender is not properly leveled it can begin to accumulate standing water, which over a period of time may begin to freeze and will eventually freeze the evaporator. Another problem that may occur from an unlevelled vender will be improper vending, which would include but not be limited to product not vending from column, product vending slow from column, product not sliding or rolling down to the delivery port, or product jamming.

**Lighting System:** The lighting system contains high voltage. Power **MUST** be disconnected when working with or around this portion of the vender. Light bulbs should be replaced whenever one or more of the bulb ends are blackened or discolored, or when the lights are flickering or are not lit, and it has been determined that the ballast is good. Replace these bulbs as soon as it is determined they are bad. If it is decided not to use the lighting system, the ballast **MUST** be unplugged. **DO NOT** remove the bulbs and leave the ballast plugged in. Doing so can cause the ballast to generate a very high amount of electrical noise, which can cause problems for or permanently damage electronic components.

**Product Chute:** Bottles or cans should never be placed under the product chute. Bottles can prevent air flow and may hinder the proper performance of the chute sensor.

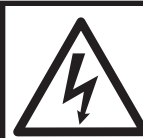

**WARNING:**  
**ELECTRIC SHOCK DANGER**  
Power **MUST** be disconnected when working with or around the lighting system.

## Section 5. Vender Maintenance

### Using the Vender's Error Code System

The MERLIN IV vender has a built-in error code diagnostic system that will help you troubleshoot and solve problems. This system is best used in conjunction with the Troubleshooting Section which follows this page. The error codes shown below consist of two codes: a main error and a detailed error. These errors are not a replacement for your knowledge of the vender or its operation. They will only point you in the general direction of the problem. Most vender parts are independent of one another. Because of this, most problems can be confined to the item in question (such as an LED display, coin changer, or select switch), the harnessing connecting it to the control board, and the control board itself. Upon opening the vender's main door, you will enter the Service Mode. The display will flash any vender error codes, or "none" if no problems exist. Errors can be cleared from the "Error" Mode within the Service Menu.

*Note: It is recommended the error codes be cleared after correcting any problem(s) to prevent confusion and unnecessary work in the future.*

### Error Codes

MAIN ERROR	DETAILED ERROR	CORRECTIVE ACTION
SELS	SS1 - SS12 (selection switch closed)	Fix stuck button / switch or replace switch.
CHAr	CC (changer communication)	Check changer harness connections.
	TS (changer tube sensor)	Consult changer manufacturer.
	IC (inlet chute blocked)	Check vender's coin chute for blockage.
	tJ (changer tube jam)	Check changer's coin tubes / tube sensors.
ACCE	CrCh (changer ROM checksum)	Consult changer manufacturer.
	EE (excessive escrow)	Check for stuck coin return lever.
	nJ (acceptor coin jam)	Check for blockage / dirty sensor in acceptor.
Chut	CS (chute sensor always on)	Adjust chute sensor. (Refer to section 2.)
StS	DAxx (double-assigned column)	Correct space-to-sales settings, if necessary.
	UAxx (unassigned column)	Correct space-to-sales settings, if necessary.
bUAL	bS (bill validator sensor)	Remove obstruction or clean sensors.
	biLL (bill validator motor)	Consult bill validator manufacturer.
	bJ (bill jam)	Remove jammed bill or clean bill sensors.
	bOPn (bill validator cash box open)	Close bill acceptor cash box.
	bFUL (bill validator cash box full)	Remove bills from cash box.
	bC (bill validator communications)	Check bill validator harness connections.
FriG	SEnS (temperature sensor)	Check for a cut / disconnected temperature sensor.
	COLd (sensing temperature 3° F / 1.5° C below cut-out)	Check for a welded contact in refrigeration relay or shorted wire from control board to refrigeration relay.
	CnPr (not cooling within 30 minutes of cut-in)	Check "FrG" in programming and all wiring connections from control board to refrigeration unit.
	ACL0 (less than 95 volts for greater than 30 minutes)	Check voltage at wall outlet during the peak of the load with all units (if any others are present in circuit) running.
	PLdn (inability to reach the set point temperature)	Check to make sure the evaporator fan motor is working. If it is, replace the refrigeration unit.

## Section 5. Vender Maintenance

# Merlin IV

## Troubleshooting

Use the following section to troubleshoot your MERLIN IV vender in the event you have a problem in one of the following areas: power, acceptance (coin or bill), vending, or refrigeration. Although we have added what we felt are the most encountered problems, your specific problem may not be here. If this is the case please, contact your local Royal Vendors service representative.

Error / Problem	Possible Cause / Test Procedure	Corrective Action
<b>COIN ACCEPTANCE / PAYOUT (RECORD ALL ERRORS ON PAPER)</b>		
Coin mechanism will not accept coins.	No power to board.	Check to make sure the LED and the sign lighting are lit. Check fuse and transformer.
	Harness from coin mech to board is cut or disconnected.	Using a voltmeter, check each wire for continuity and to ground.
	Short in coin mechanism.	Unplug all connections from the control board except the transformer and coin mech connections. Test acceptance. If it accepts, replug each connection one at a time and test acceptance after each.
	Acceptor is dirty or other problem may exist (not tuned).	Clean acceptor or contact your local coin mech distributor.
	Short in control board.	If above procedures do not work, replace control board.
No acceptance or rejects a percentage of good coins.	Coin return lever pressing down on acceptor's coin plunger.	Make sure changer is mounted correctly and the coin return lever is in the proper position.
	Acceptor is dirty or foreign matter is in the path.	Clean acceptor or contact distributor.
	Coin changer is improperly tuned (if tunable).	Contact manufacturer for tuning.
	Defective control board.	Replace / test control board.
Always accepts coins but gives erratic / no credit.	IF NO CREDIT: Defective harness between coin mech and control board (will have "CC" error).	Check harness for cut wires or wrong / bad connections. Test each wire for continuity or test to ground. If found to be defective, replace the harness.
	IF ERRATIC OR NO CREDIT: Acceptor or coin mech.	Replace coin mech and test.
	IF NO CREDIT: Defective control board.	Replace control board.
Changer will not pay out coins. <i>(continued on next page)</i>	Defective harness from coin mech to control board.	Test vender's manual coin payout. If vender won't pay out using the CPO mode or during sales, check harness for cuts, bad continuity, or wrong connections. If defective, replace and test.
	Defective coin mech.	Replace coin mech and test. If it pays out, the coin mech was defective.
	Defective control board.	If coin mech won't pay out coins manually in the CPO mode or during the Sales Mode and the above procedures have failed, replace the control board and test payout both in the CPO mode and during a sale.

## Section 5. Vender Maintenance

Error / Problem	Possible Cause / Test Procedure	Corrective Action
Changer will not pay out coins. <i>(continued from previous page)</i>	Change payout buttons are disabled while door is closed or while in Open-door Mode.	Enter the Service Mode or access the Coin Payout Mode ("CPO").
<b>BILL ACCEPTANCE</b>		
Bill acceptor won't pull bill in.	No power to validator.	Unplug vender for 10 seconds and replug to see if bill acceptor cycles. If not, check acceptor harnessing or replace the bill acceptor.
	Wrong acceptor harness or wires of the harness are in the wrong position.	Make sure that the acceptor harnessing is correct for your style of acceptor and that it is wired properly.
	Acceptance disabled by coin mech (if present), or bad harnessing.	Make sure that the coin mech is plugged in (accepts coins) and that the coin tubes have enough coins to enable bill acceptance.
	Coin mech is not operative.	Make sure that the changer harnessing is correctly connected and has continuity. Repair or replace if necessary.
	Replace acceptor and test. If acceptor pulls bill in, acceptor was defective.	Replace bill acceptor.
Bill acceptor takes a bill but will not establish a credit.	Defective acceptor harness (credit not getting from acceptor to control board through the harness).	Make sure that the acceptor harnessing is correct for your style of acceptor and it is plugged in / wired properly.
	Defective acceptor.	Replace / test acceptor.
	Defective control board.	Replace / test control board.
Bill acceptor takes a bill and credits, but credit will not erase.	Defective / wrong acceptor interface harness.	Refer to bill acceptor service manual or bill acceptor representative.
	Defective bill acceptor.	Replace acceptor, and test acceptance and erasure of credit.
	Defective control board.	Replace / test control board for erasure of credit.
Accepter takes a bill and allows payback of coins without a selection.	Controller configurations not set properly.	Access vender configurations mode and check the Forced Vend Attempt setting.
<b>VENDING PROBLEMS</b>		
Multiple vending (not cancelling credit)	If multiple vending is from all selections, delivery sensor is cut or improperly grounded. <b>NOTE: If the sensor is not present or is cut (defective), the controller will allow up to two products from each column assigned to be vended before the column is determined to be sold out.</b>	Factory adjustment for the trim pot screw on the controller: 1. Turn screw clockwise until the light comes on. 2. Turn screw counterclockwise until the light goes out. 3. Continue turning counterclockwise 1 full turn. 4. Vend test on columns 7 and 12, and watch the light on the board. Make sure the only time the light comes on is when a product hits the can chute.
	Depth setting not set correctly in "SdEP" mode (may be set to single depth).	Enter "SdEP" mode and check the setting to make sure it is correct. Refer to "SdEP" section of this manual. <b>NOTE: "SdEP" is <u>always</u> set by selection number.</b>
	Mechanical error.	Check the vend motor to ensure the gearing within it is okay. If not, replace the vend motor.

## Section 5. Vender Maintenance

Error / Problem	Possible Cause / Test Procedure	Corrective Action
Wrong product vending upon selection.	Misload by vender loader.	Ensure that all product within each column is the same.
	Space-to-sales not set properly.	Look for StS error. Check or reset space-to-sales.
	Miswired motor.	Check the wiring at each vend motor, at the bottom of the vender's main door, and at the motor connection on the control board to ensure the wires are in the correct order.
	Miswired selection.	Check the wiring from the control board to the selection switches.
No vend upon selection. Dry vend (no refund).	Chute sensor too sensitive, or a column is jammed or sold out.	Check to see if the delivery chute sensor adjustment LED is constantly on. If so, adjust it back to factory setting. See "Delivery Chute Sensor" in Section 2.
	Defective chute sensor.	Unplug the sensor's connection from the control board. Watch the LED. If the adjustment LED goes out, replace the defective sensor.
	Defective control board.	If the adjustment LED stays on after unplugging the sensor from the control board, power it down (pull the fuse), and unplug everything from the control board except the main power lead. Reinsert the fuse. If the adjustment LED immediately lights up, turn the screw counterclockwise to see if the light goes out. If not, replace the control board.
Will vend from some but not all columns (allows refund or second choice).	Select button, switch, or harnessing.	Check the selection switch. Trace the selection harness back to the control board. Replace if necessary.
	Defective vend motor harnessing.	Trace the individual wire that runs from the motor connection of the control board to the vend motor of the defective column. If the wire is cut or pinched, repair or replace the wire / harness.
	Defective control board.	Measure the voltage at the vend motor's connection at the control board. Measure it on the individual wire for the motor attempted and the wire itself next to the key (neutral). A selection must be made and "hoLd" displayed on the LED. 24 VDC should be registered. If not, replace the control board.
Complete sold-out condition.	Timer is enabled or "StS" has been cleared.	Disable timer control. Check space-to-sales settings; reprogram if necessary.
	Door switch not working.	Open the vender's main door, and make sure the LED displays the Service Mode. If not, check for voltage (5 VDC) with a voltmeter at the door switch. If voltage is found, replace the door switch. If not, check for voltage (5 VDC) at the door switch's pinout on the control board. If no voltage is found there, replace the control board.

## Section 5. Vender Maintenance

Error / Problem	Possible Cause / Test Procedure	Corrective Action
<b>MISCELLANEOUS PROBLEMS</b>		
Display shows "Sold Out" immediately upon pressing selection button of a full column (sold-out condition not clearing).	Door switch wiring incorrectly connected or cut / pinched.	Check for cuts on the two door switch wires going from the switch to the control board. Also, check for bad connections.
	Door switch.	Check the door switch to see if it is defective. Use a voltmeter to measure for voltage between the COM / NO positions and COM / NC positions.
	Control board.	Check the control board by checking voltage across the two pins for the door switch on the board. If no voltage is found, replace the control board.
Vender appears dead; no digital display and no lights.	Defective main harness. Secondary power harness to the transformer. Lights defective.	Replace main wiring harness. Replace secondary power harness. (See interconnect drawing.)
No digital display; vender lights are on.	Transformer not properly connected or defective.	Check transformer connection. Check power with voltmeter from transformer to control board. (See interconnect drawing.) Replace if necessary.
	Defective display or display harness.	Check display and display harness. Replace if necessary.
	Defective control board.	Replace control board.
Vender scrolls message on display but does not accept money.	Changer out of tune.	Refer to changer manual or contact distributor.
	Defective changer.	Replace changer.
	Defective control board.	Replace control board.
Vender accepts money but does not establish credit.	Defective changer.	Replace changer.
	Defective control board.	Replace control board.
Vender accepts and credits money but does not vend (does not indicate a sold-out condition).	Defective selection switch.	Check selection switch. Replace if necessary.
	Defective selection switch harness.	Check harness. Replace if necessary.
	Defective control board.	Replace control board.
Flashing 8's across the LED.	Chips on control board not seated properly.	Seat the chips properly.
	Bad LED connection.	Scrape the pins on the LED and reinstall harness.
	Defective control board.	Unplug everything from the control board except the LED and main power. If the 8's remain, replace the control board.
	Defective components.	If the 8's have disappeared from the previous step, begin plugging in harnesses one at a time. Replace whatever causes the 8's to reappear.
Solid 8's across the LED.	Defective LED.	Replace LED and / or harness.
	Defective control board.	Replace control board.
"Out of Order" on the LED.	Corrupted control board.	Press the service mode button. Wait approximately 20 seconds for the board to reset. Reprogram the control board. If the problem reappears or the board cannot be reprogrammed, replace the control board.

## Section 5. Vender Maintenance

Error / Problem	Possible Cause / Test Procedure	Corrective Action
<b>ELECTRONIC REFRIGERATION</b>		
Refrigeration unit will not run. The cabinet temperature reads 255°F / 124°C or 17°F / -8.5°C.	Defective temperature sensor.	<ol style="list-style-type: none"> <li>1. Check connection.</li> <li>2. Replace temperature sensor.</li> </ol>
Vender will not display a temperature when "dSP" is set to "1."	Unplugged temperature sensor.	Make sure temperature sensor is securely plugged in at control board.
	Defective temperature sensor.	Unplug the existing sensor, and plug the new sensor up. Ground the new sensor to the board. Hold down the door switch, and see if the LED displays a temperature.
	Defective control board.	If it does not display a temperature, replace the control board.
Refrigeration unit will not run.	Defective unit.	Plug the unit directly to the wall outlet to see if it runs and cools. If not, then replace the unit. <b>(DANGER: ELECTRIC SHOCK HAZARD. When plugging in the refrigeration unit directly to a wall outlet or other power source, always ensure that the vender itself is also plugged in to a grounded electrical outlet. Failure to do so could cause an electrical shock, possibly resulting in severe injury or even death.)</b>
	"FrG" setting not set properly.	Check "FrG" setting in the "FriG" mode to make sure it is set to "1." If set incorrectly, reprogram it to show "1."
	Cut-in / cut-out settings not set properly.	Check cut-in / cut-out settings. If set incorrectly, reprogram them.
	Temperature sensor not reading correctly.	Test the temperature sensor by showing the temperature on the display and measuring the actual inside cabinet temperature with a thermometer or by opening / closing the door to see if the temperature changes. If found defective, replace the temperature sensor.
	Short in wiring harness from the control board to the refrigeration relay.	Unplug the wires coming from the control board and measure the voltage in relay test mode. Approximately 24 VDC should be registered. If not, locate the shorted wire, and correct or replace the defective harness.
	Refrigeration relay is defective.	Test the relay by making sure all connections are made for the refrigeration unit, the refrigeration relay, and the control board. Next, go into the "FriG" mode. Check the compressor by pressing <b>&lt;enter&gt;</b> at "CnPr," then press <b>&lt;enter&gt;</b> again when the display flashes "CnPr" / "On." If the unit does not come on, replace the relay.
	Unit will only run in the compressor relay test mode.	Defective door switch.
Defective temperature sensor.		Set "dSP" to "1" in Refrigeration Mode. If the temperature shown is inaccurate, replace the temperature sensor.
Wait for the delay after the door is closed (5 to 10 minutes).		Wait to see if the unit comes on. If not, replace the control board.

## Section 5. Vender Maintenance

Error / Problem	Possible Cause / Test Procedure	Corrective Action
Unit will not run in the compressor relay test mode. <b>NOTE:</b> Leave the compressor relay test mode on in order to check for voltage with the voltmeter.	Defective control board.	Check for 24 VDC with a voltmeter across pins 1 and 3 of the control board. If no voltage or incorrect voltage is found, replace the control board.
	Defective relay harness.	Check for 24 VDC with a voltmeter at the relay across the two wires with pink connectors. Replace if incorrect.
	Defective relay.	Check for 115 VAC on the contact side of the relay with a voltmeter. Replace if incorrect.
Refrigeration unit runs constantly.	Defective door switch.	Upon opening the door, the LED should not show "Ice Cold...". If it does, check the door switch wiring. Replace the door switch if necessary.
	Defective control board.	Replace the control board.
	Defective relay. Contacts are welded together.	Unplug one of the wires with the pink connectors from the relay. Also unplug the 115 VAC side of the relay. If the unit cuts off, replace the relay.
	Defective main power cord.	If the unit continues to run after unplugging everything from the relay, replace the main wiring harness (junction block).
Evaporator freeze-up.	Check the steps above if the unit runs when the door is open.	See above.
	Evaporator fan not running.	Check the wiring to the evaporator fan. Check for 115 VAC with a voltmeter. If no voltage is found, replace the junction block. If the correct voltage is found, replace the evaporator fan motor.
	Air leaks around the inner door or port body.	Check for condensation around the inner door for air leaks. Ensure the door is tightened down far enough. Make sure the port door is not held open.
	Mullion area not properly sealed (area where the harnesses enter the cabinet).	Apply permagum.
	Drain tube clogged.	Check to make sure water can freely flow through the drain tube.
	Cut-in / cut-out set too low.	Increase "Cuti" / "Cuto."
	Refrigeration unit low on coolant.	Replace refrigeration unit.

# Section 5. Vender Maintenance

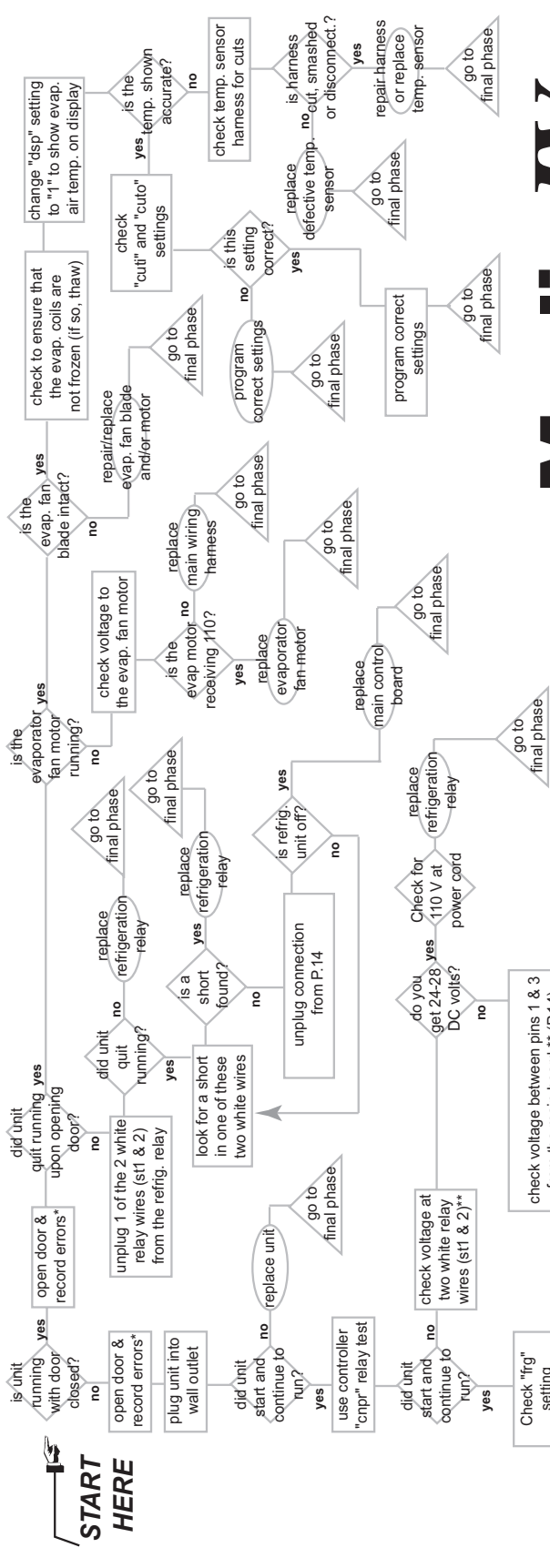

## Merlin IV REFRIGERATION TROUBLESHOOTING FLOW CHART



**ELECTRIC SHOCK DANGER**  
When plugging in the refrigeration unit directly to a wall outlet or other power source, always ensure that the vender itself is also plugged in to a grounded electrical outlet. Failure to do so could cause an electrical shock, possibly resulting in severe injury or even death.

\*normal errors are "cnpr" and "cold" for this type of problem.  
\*\*for voltage to be read, you must first enable the compressor (via the "rely" mode.  
\*\*\*for this type of problem it is recommended that the settings be 41 (cut) & 29 (cuto)

Note: Temperature Sensor tolerance is +/- 1 degree F

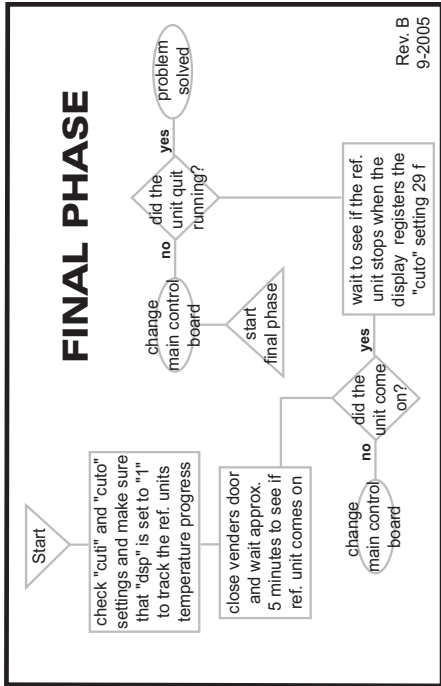

Rev.B  
9-2005

## Section 6. Training Guide

# Training Guide

### Troubleshooting Technique

**Objective:** Understand sequence of operation, identify what vender is doing, and compare to what it should be doing.

- Find defective component, confirm failed component, repair / replace component, test to confirm fix;
- Identify source, path, or load;
- Distinguish between software and hardware;
- Repair the problem, not the symptom.

### Simple circuit

- Power supply (source - *example: control board*)
- Line (path - *example: display harness*)
- Device (load - *example: LED display*)
- Failure of any one results in service call.
- Skill required is systematic, logical process of elimination.
  1. Do I have power?
  2. Can the power get to where I want it?
  3. Does the device work?
- Confirm through use of volt / ohm meter.
- Understand the impact of software on hardware.
- Test to confirm repair.
- Low-voltage circuits are affected by harness connections, insulation, line noise, polarity, and ground.
- The meter is *not* an option when checking low-voltage circuits.

### Component Highlights

#### Control board

- “Brains” of vender
- Controls all vending operations
- See *Chapter 2: Vender Component Explanation* for full explanations of control board pinouts and functions.

#### Power Supply (See Figure 6.1)

- Supplies 24 VAC ( $\pm 10\%$ ) to control board
- Only AC voltage at control board
- Check for primary voltage to transformer at lamp ballast harness
- Check for secondary voltage across position P15, pins 1 and 2
- Secondary is protected by a 3-amp fuse
- Ohm-out fuse holder

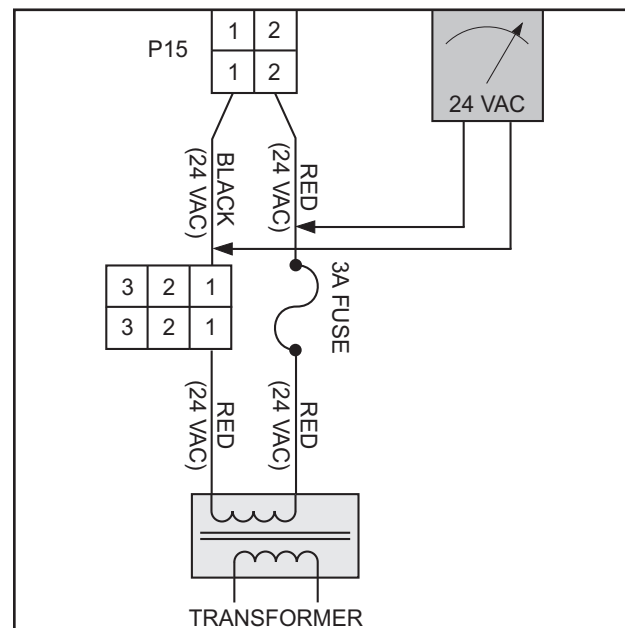

Figure 6.1 - Power Supply

# Section 6. Training Guide

## LED Harness (See Figure 6.2)

- Supplies 5 VDC to LED
- Check for 5 VDC across position P1, pins 1 and 4
- Ohm-out harness

## Multi-Drop Bus (MDB) Harness (See Figure 6.3)

- Supplies 24 VDC to changer, validator, and / or card reader from position P3, pins 1 and 6
- Data transmitted and received by control board
- Confirm with changer, LED on; payout works
- Multiple harnesses may be connected in series for more peripherals - check all harnesses

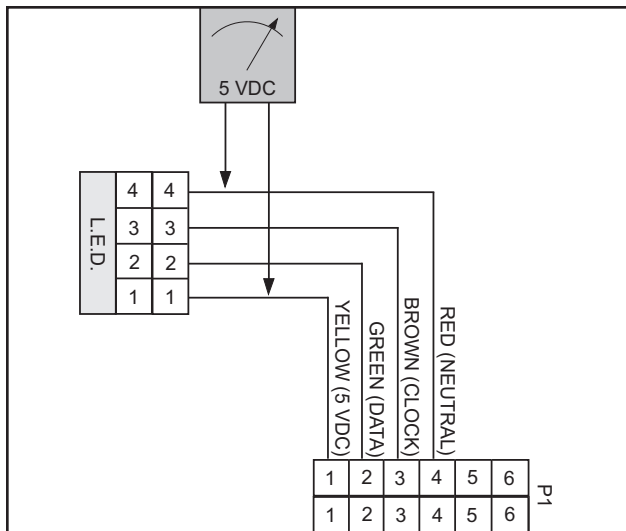

Figure 6.2 - LED Harness

## Chute Sensor (See Figure 6.4)

- Position P4 on control board
- Low-voltage (5 mV @ 500 μSeconds) impact sensor
- Voltage returned from chute sensor, signaling control board to cancel credit and reset
- Trimpot (R19 on control board) is used to increase or decrease sensitivity

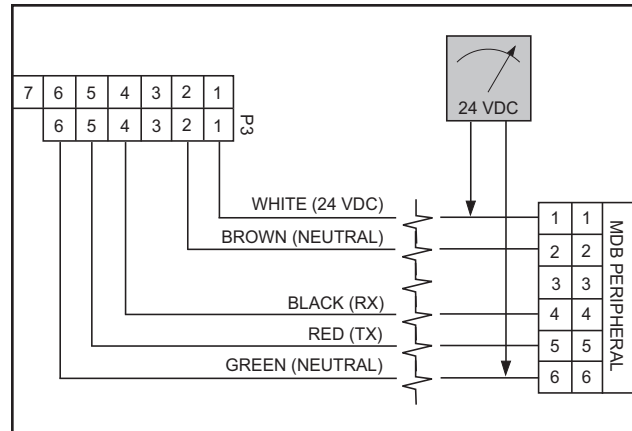

Figure 6.3 - MDB Harness

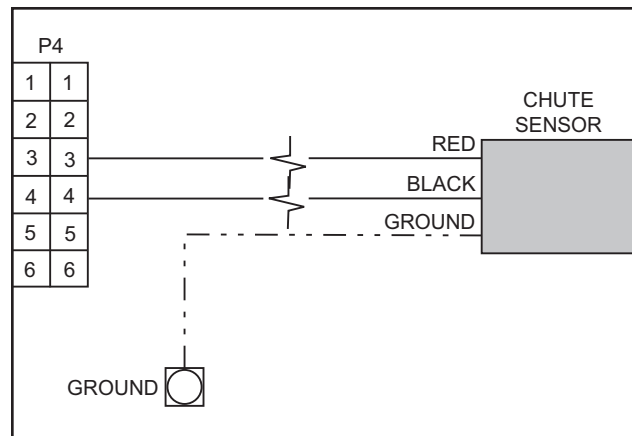

Figure 6.4 - Chute Sensor Harness

# Section 6. Training Guide

## Select Switch Harness (See Figure 6.5)

- Supplies 5 VDC to select switches from position P7, pin 11
- Press select button and watch LED reset
- Signal from switch via N.O. terminal
- Check with ohm-meter

## Vend Motor Harness (See Figure 6.6)

- Vend motor power supply - 24 VDC from pin 14 at position P8
- Neutral side is closed, cycles vend motor
- If vend motors to right do not vend, check black wire (24 VDC) from last working vend motor
- If one single motor does not work, check neutral

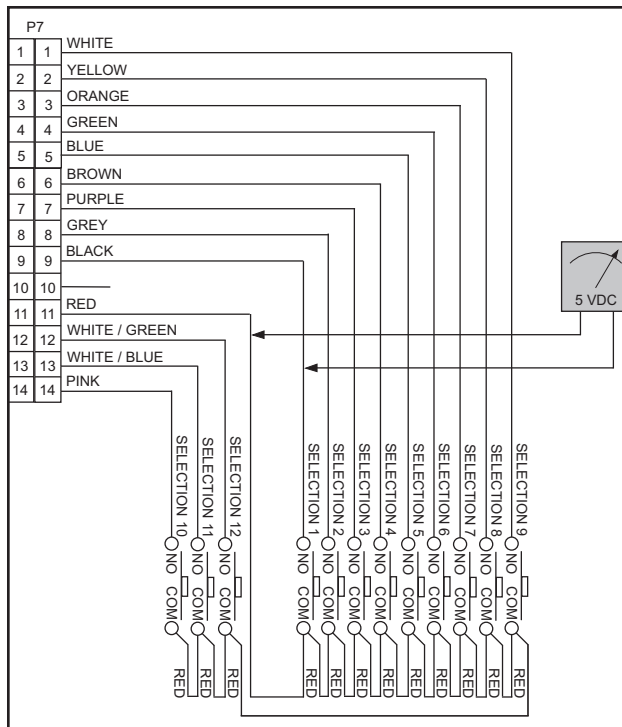

Figure 6.5 - Select Switch Harness

## Door Switch / Options Harness (See Figure 6.7)

- Supplies 5 VDC from position P9 to door switch (pins 1 and 6) and to options harnesses (free-vend switch, no-vend switch, etc.)
- Door switch:
  1. Updates door status to control board (open / closed)
  2. Depress switch, check to see if LED resets
  3. Check wires at switch for correct positions
- Options switches:
  1. Allow free-vend, no-vend, etc.
  2. 5 VDC on pins 6 and pin for option switch (see wiring diagram)

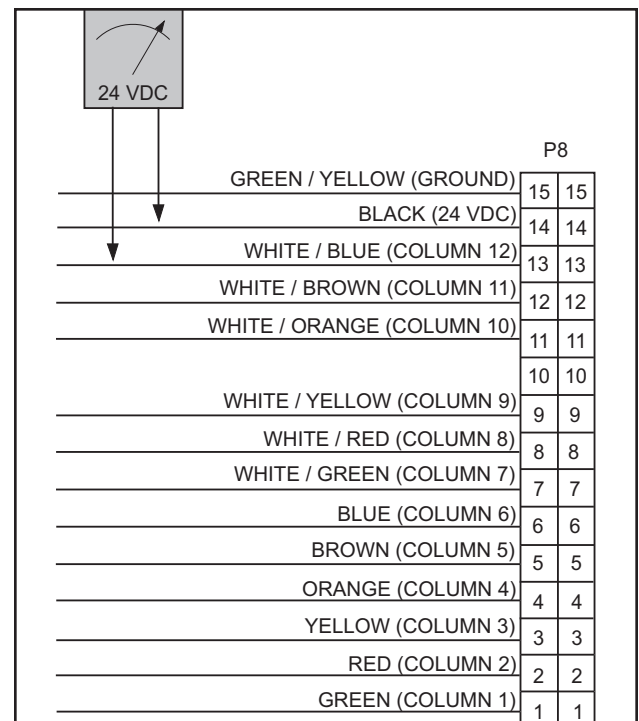

Figure 6.6 - Vend Motor Harness

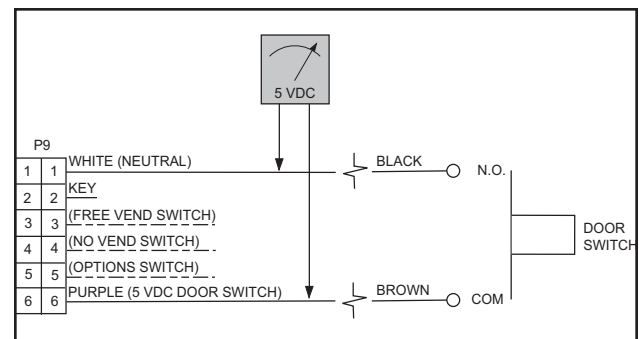

Figure 6.7 - Door Switch / Options Harness

# Section 6. Training Guide

## DEX / UCS Harness (See Figure 6.8)

- Located at positions P10 (Internal) and P11 (External)
- Computer access point
- Internal: read / write anytime; standard item
- External: read anytime; can only write when door switch is open; optional item

## Temperature Sensor Harness (See Figure 6.9)

- Supplies 5 VDC to temperature sensor from position P12, pins 1 and 4
- 5 VDC from pins 1 and 4
- <5 VDC return resistance across pins 1 and 2
- Set to display temperature on LED, compare to thermometer
- Temperature sensor mounted on rear of cabinet

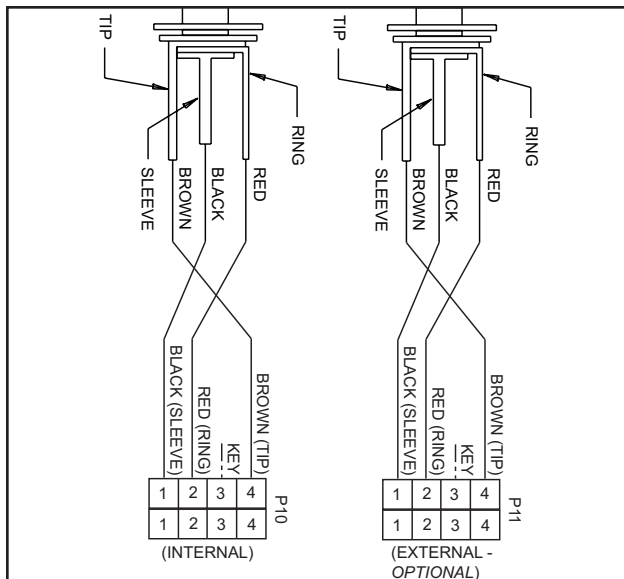

Figure 6.8 - DEX / UCS Harness

## Environmental Control (Refrigeration) Harness (See Figure 6.10)

- Supplies 24 VDC to refrigeration relay from position P14, pins 1 and 3
- Check for 24 VDC in relay test mode
- Harness also used for connections to evaporator fan relay, heater relay, and light relay
- Allows relay to energize and close contacts to complete 110 VAC hot circuit

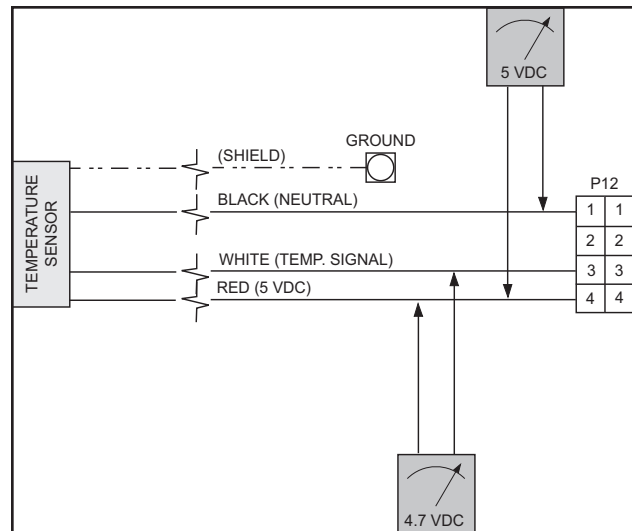

Figure 6.9 - Temperature Sensor Harness

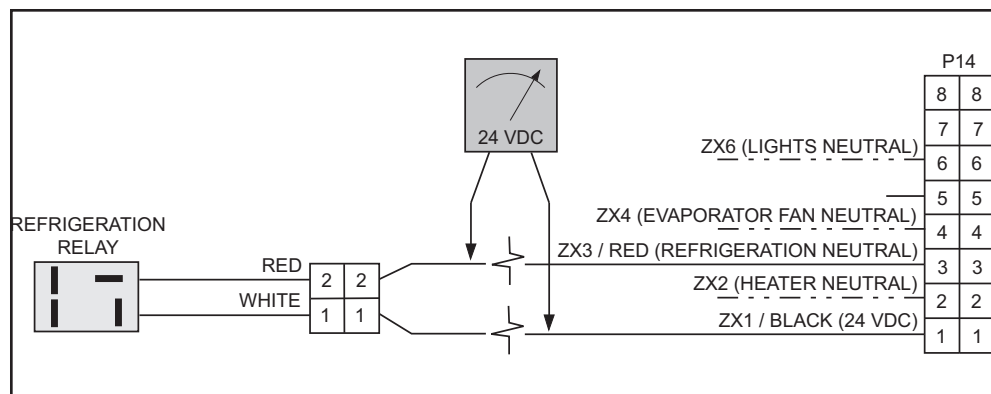
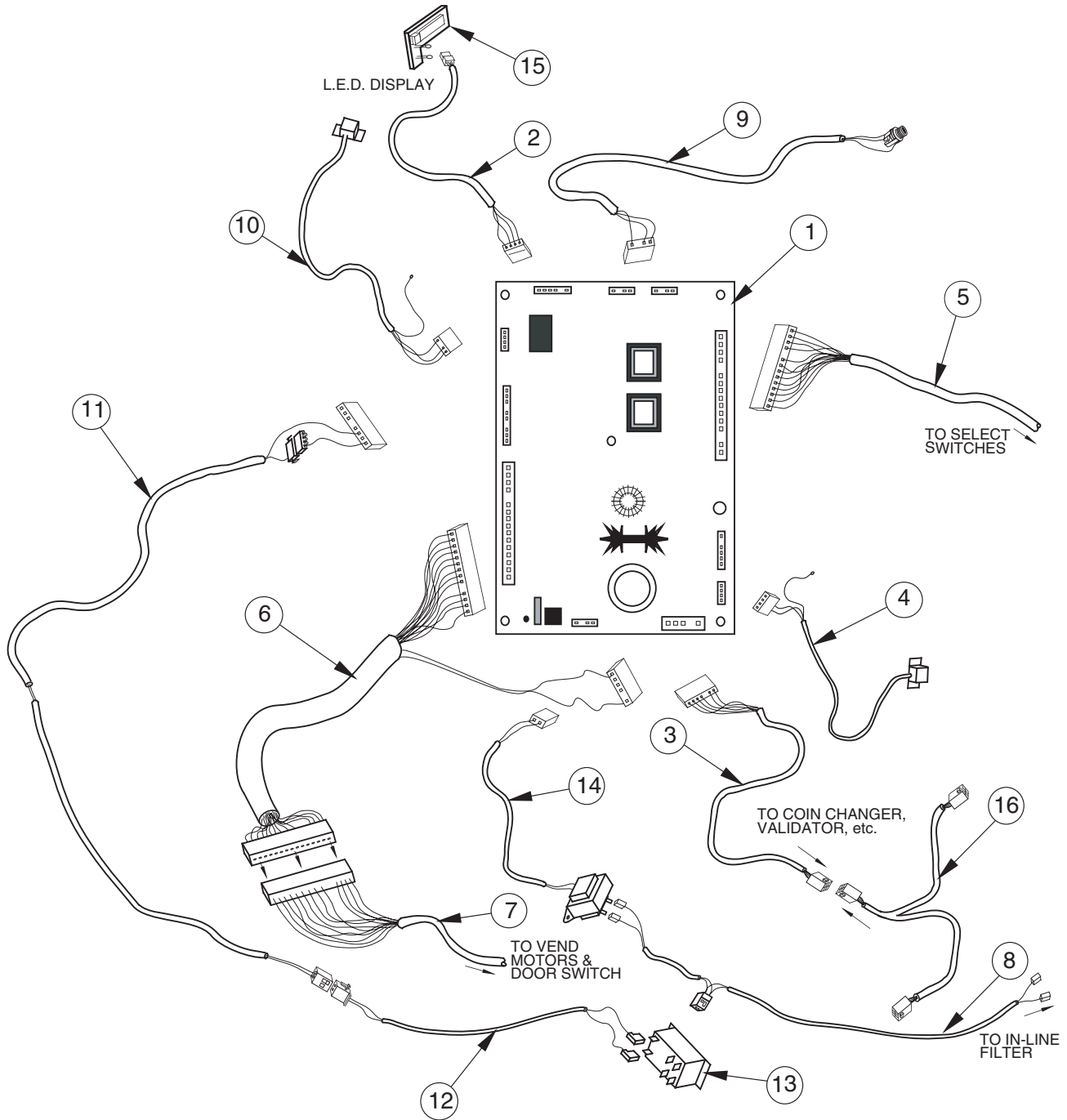

Figure 6.10 - Environmental Control Harness

# exploded views

# Section 7. Exploded Views and Part Numbers

## Control Board and Wiring



## Section 7. Exploded Views and Part Numbers

---

### Control Board and Wiring

ITEM NUMBER	DESCRIPTION	PART NUMBER
1	Control Board.....	836182
2	LED Display Harness.....	842081
	- LED Harness, Dr. Pepper.....	842326
3	Serial Changer Harness .....	842079
4	Delivery Sensor (includes harness), Piezo.....	210121
	- Impact Sensor ( <i>older style</i> ).....	836004
5	Select Switch Harness, Pepsi Cola 10 Select .....	842190
	Select Switch Harness, Live Display Vender.....	842192
	Select Switch Harness, Dr Pepper Vender.....	842201
6	Main Door Harness (vend motor/door switch wiring).....	842169
7	Cabinet Harness, 12 Column Mechanism (Wide).....	842174
	Cabinet Harness, 10 Column Mechanism (Narrow).....	842231
	-1521 and after (Wide).....	842230
	-1521 and after (Narrow).....	842231
8	Merlin IV Harness Assy. 117V Line.....	842151
9	Internal HH. Phone Jack and Harness .....	842099
10	Temperature Sensor (includes harness).....	822030
	- Temperature Sensor Mounting Bracket, 200722 and after ( <i>below chute assembly</i> ).....	286002
11	Relay Harness, Refrigeration, Door Side.....	842236
	- Evaporator Fan, Door Side.....	842281
12	Relay Harness, Refrigeration, Cabinet Side.....	842237
	- Evaporator Fan, Cabinet Side.....	842623
13	Refrigeration Relay, New Style (4-prong).....	836130
	- Old Style (6-prong).....	836065
14	Transformer Assembly.....	842147
	Merlin IV Harness, Transformer and Fuse to Board.....	842210
	Fusebox Assembly.....	842219
15	LED Display.....	836012
16	MDB Harness .....	842116
•	Control board housing.....	261570

# Section 7. Exploded Views and Part Numbers

## Port Assembly

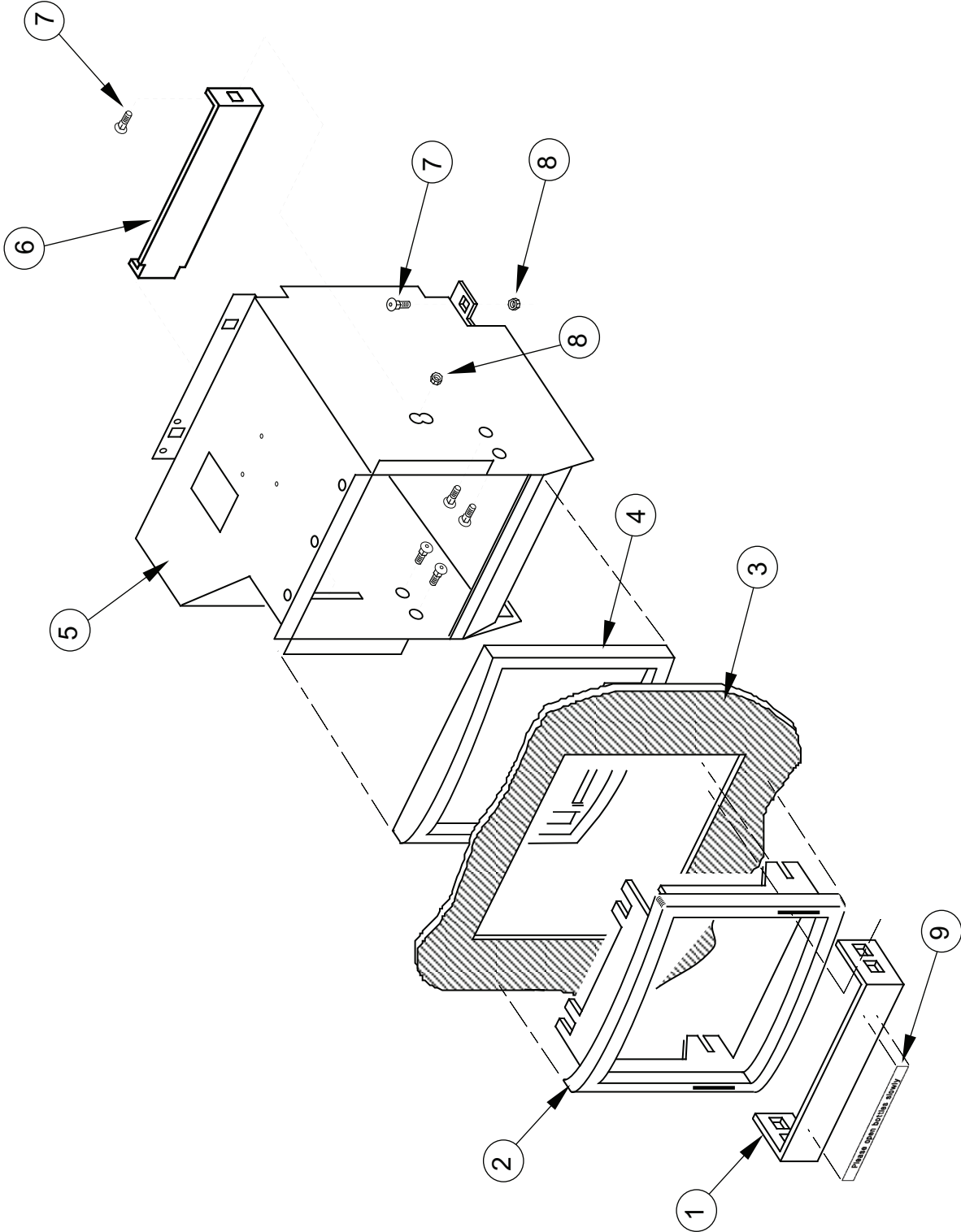

## Section 7. Exploded Views and Part Numbers

---

### Port Assembly

ITEM NUMBER	DESCRIPTION	PART NUMBER
1	Can Stop.....	010508
	Can Stop (Wide Port).....	273508
2	Port Trim .....	815019
	Port Trim (Wide Port).....	815249
3	Sign.....	SEE NOTE
4	Port Spacer.....	815020
	Port Spacer (Wide Port).....	815248
5	Port Body W/A, Merlin IV Narrow Venders .....	273510
	Wide Port W/A, CDC .....	303510
	Wide Port W/A, Non-CDC .....	305510
6	Anti Theft Plate, Non CDC Wide.....	305501
	- CDC Wide.....	303503
7	Bolt 1/4-20 .....	901007
8	Nut 1/4-20 .....	905002
9	Anti-Foaming Label.....	931355
•	Enclosed Coin Cup Kit (wide).....	303150

**NOTE:** There are various parts. Please specify model and serial number at the time of order.

# Section 7. Exploded Views and Part Numbers

## Inner Door Assembly

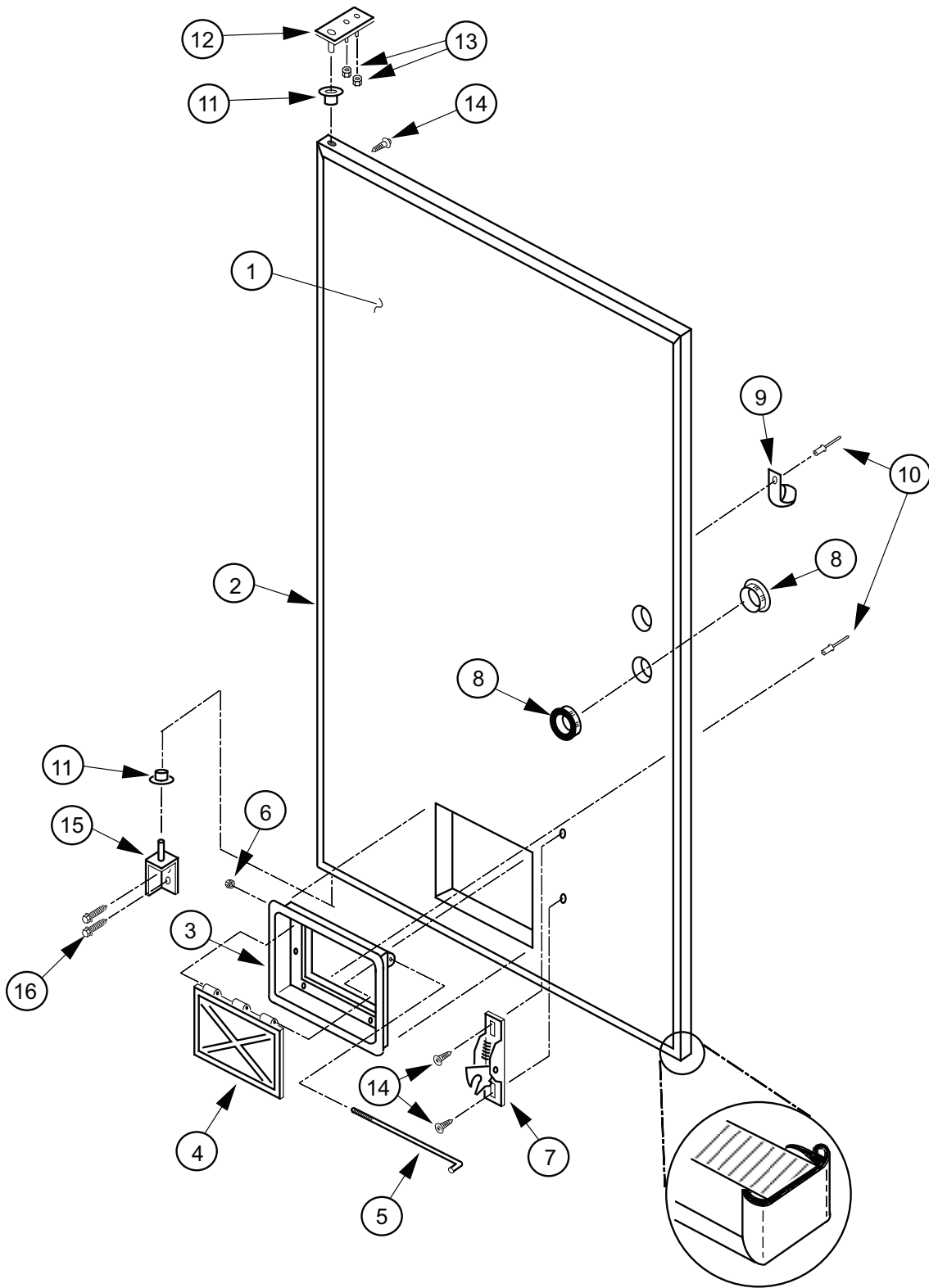

## Section 7. Exploded Views and Part Numbers

---

### Inner Door Assembly

ITEM NUMBER	DESCRIPTION	PART NUMBER
1	Inner Door Assembly 79" Wide Venders.....	261640
	Inner Door Assembly 79" Narrow Venders.....	258630
	Inner Door Assembly 79" Dr Pepper Vision 4.....	271640
	Inner Door Assembly 72" Wide Venders.....	262642
	Inner Door Assembly 72" Narrow Venders.....	264630
	Inner Door Assembly 72" Dr Pepper Vision 4.....	272640
2	Inner Door Gasket 79" Wide Venders.....	815033
	Inner Door Gasket 79" Narrow Venders.....	815218
	Inner Door Gasket 72" Wide Venders.....	815032
	Inner Door Gasket 72" Narrow Venders.....	815219
3	Port Door Frame.....	815191
4	Port Door.....	815192
5	Port Door Rod.....	811028
6	Elastic Stop Nut.....	905006
7	Burst Open Latch.....	812002
8	Bushing, 1.37".....	916003
9	Cable Clamp.....	916004
10	1/8" Rivet.....	908002
11	Inner Door Bushing.....	815026
12	Inner Door Hinge (Top).....	010520
13	Nut, 8-32.....	905001
14	Self Drilling Screw W/ Washer.....	902001
15	Inner Door Hinge, Bottom.....	010550
16	Self Tapping 1/4 - 20 X 1".....	901003
•	Space to Sales Decal M-IV (10 column vender).....	931301
•	Space to Sales Decal M-IV (12 column vender).....	931302

# Section 7. Exploded Views and Part Numbers

## Main Door Hinge, Lifter, & T-Handle Assemblies

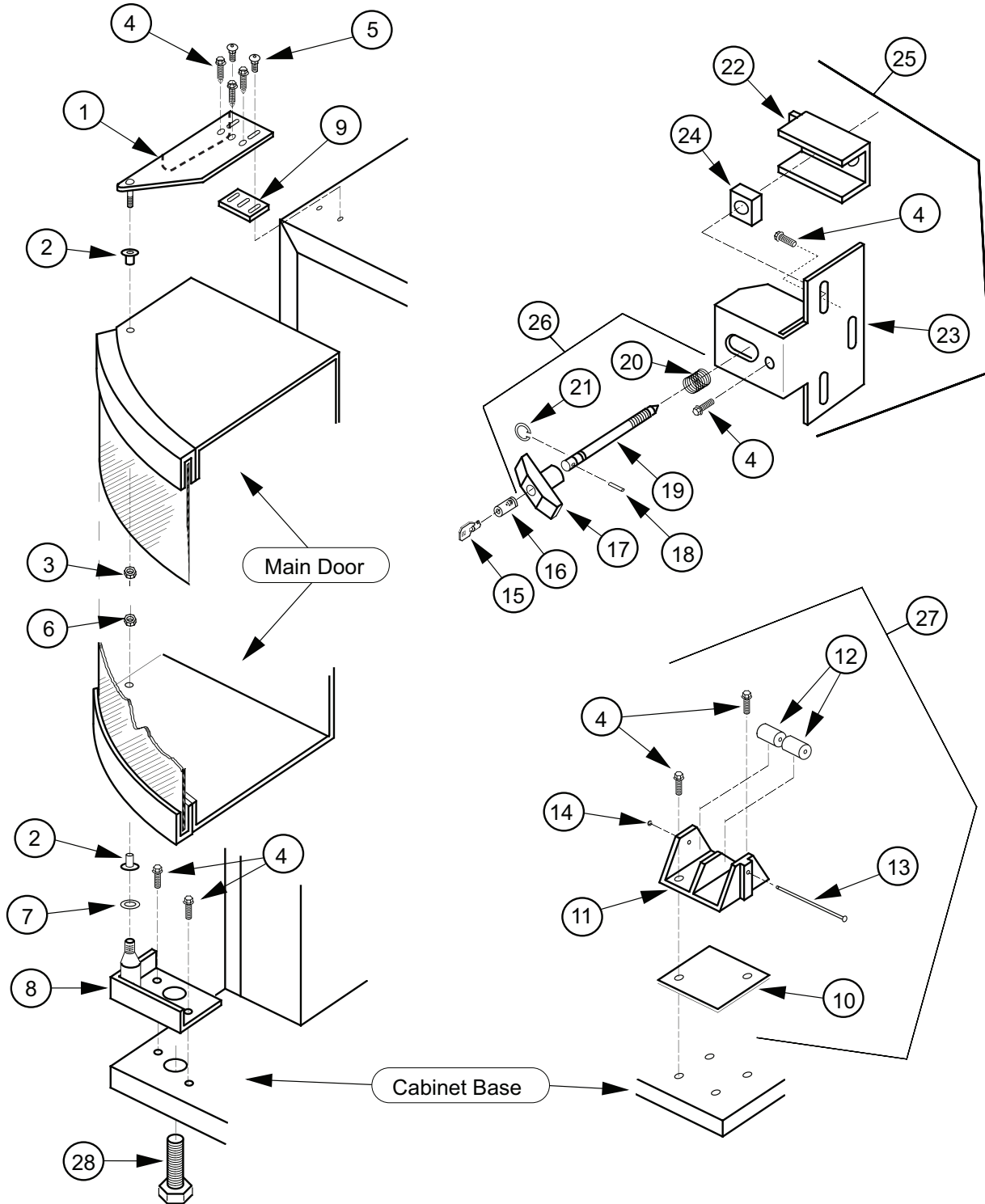

## Section 7. Exploded Views and Part Numbers

### Main Door Hinge, Lifter, & T-Handle Assemblies

ITEM NUMBER	DESCRIPTION	PART NUMBER
1	Universal Hinge .....	164550
	-Top Hinge .....	810002
2	Bearing Nyliner .....	916012
3	5/8" Keps Nut.....	905016
4	Self Tapping 1/4 - 20 X 1" .....	901003
5	Carriage Bolt 1/4 - 20 X 1 1/4" .....	901008
6	Keps Nut 1/4 - 20.....	905002
7	Flat Washer .....	904002
8	Bottom Hinge Bracket W/A.....	010040
9	Top Hinge Spacer .....	010016
10	Door Roller Spacer .....	010015
11	Door Roller Bracket .....	SEE NOTE #2
12	Door Roller.....	SEE NOTE #2
13	Door Roller Pin .....	SEE NOTE #2
14	Retainer Ring 5/32".....	906005
15	Key.....	SEE NOTE #1
16	Lock .....	SEE NOTE #1
17	T-Handle Body.....	SEE NOTE #2
18	Pin.....	SEE NOTE #2
19	"T" Handle Stud .....	SEE NOTE #2
20	Spring .....	SEE NOTE #2
21	Retainer Ring.....	SEE NOTE #2
22	Nut Retainer.....	010028
23	Latch Strike, Merlin IV.....	SEE NOTE #2
24	Square Nut 3/4 X 1/2 - 13.....	905005
25	Latch Strike Assembly, Merlin IV (Prior to 1521) .....	010030
	- 1521 and after .....	281010
26	"Flush Mount" T-Handle Assy used w/ CDC (Prior to 1521) .....	812176
	-1521 and after .....	812289
27	Door Roller Assembly .....	141180
28	Leveling Leg .....	803002

**NOTE #1:** There are various parts. Please specify model and serial number at the time of order.

**NOTE #2:** This part is not available individually. It must be ordered as an assembly.

# Section 7. Exploded Views and Part Numbers

## Refrigeration System Assembly

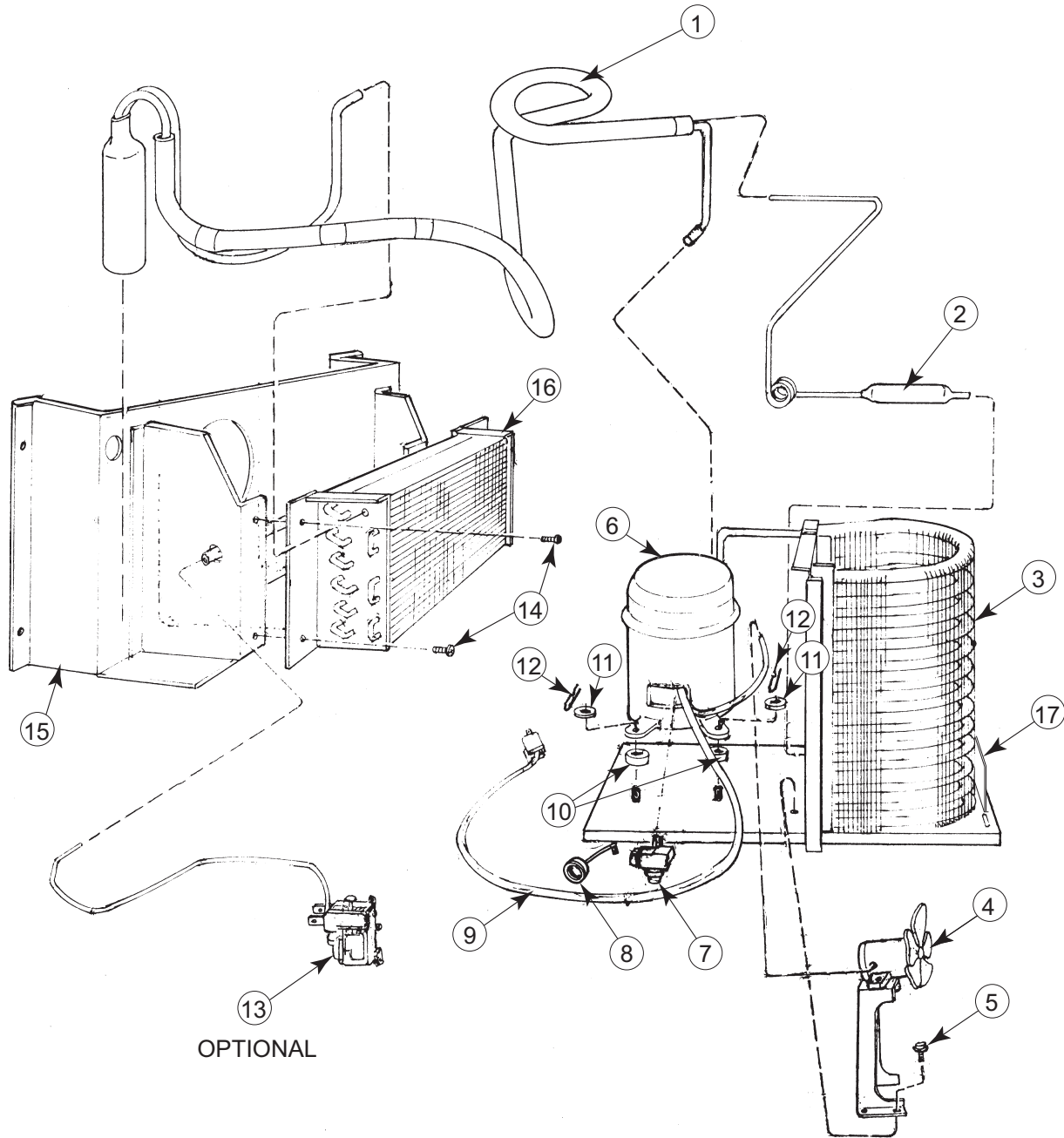

## Section 7. Exploded Views and Part Numbers

---

### Refrigeration System Assembly

ITEM NUMBER	DESCRIPTION	PART NUMBER
1	Heat Exchange .....	210425
2	Dryer .....	824005
3	Condenser .....	820007
4	Condenser Fan Motor .....	839010
	Condenser Fan blade .....	810014
	Condenser Fan Motor Bracket.....	810006
5	Screw, #8-32x1/2" .....	901006
6	1/3+ H.P. Capacitor Start Compressor .....	819028
7	Compressor Relay 1/3+ H.P. (Tecumseh Only) .....	822042
8	Compressor Overload 1/3+ H.P. (Tecumseh Only).....	822010
9	Compressor Lead .....	SEE NOTE
10	Grommets, Compressor .....	916015
11	Grommets Plugs .....	815017
12	Clip, Compressor .....	914002
13	Thermostat.....	822001
14	Screw, #8x1/2" .....	902004
15	Evaporator Fan Shroud Assembly, Airflow, Wide.....	256035
	Evaporator Fan Shroud Assembly, Wide (prior to 200422) .....	256080
	Evaporator Fan Shroud Assembly, Airflow, Narrow .....	264030
	Evaporator Fan Shroud Assembly, Narrow (prior to 200422) .....	258070
16	Evaporator Coil .....	820002
17	Refrigeration System, Merlin IV 1/3+ H.P. ....	256420
•	Evaporator Cover.....	256004
•	Condenser Shroud.....	095401

**NOTE:** This part is not available individually. It must be ordered as an assembly.

# Section 7. Exploded Views and Part Numbers

## Evaporator Fan Motor Assembly

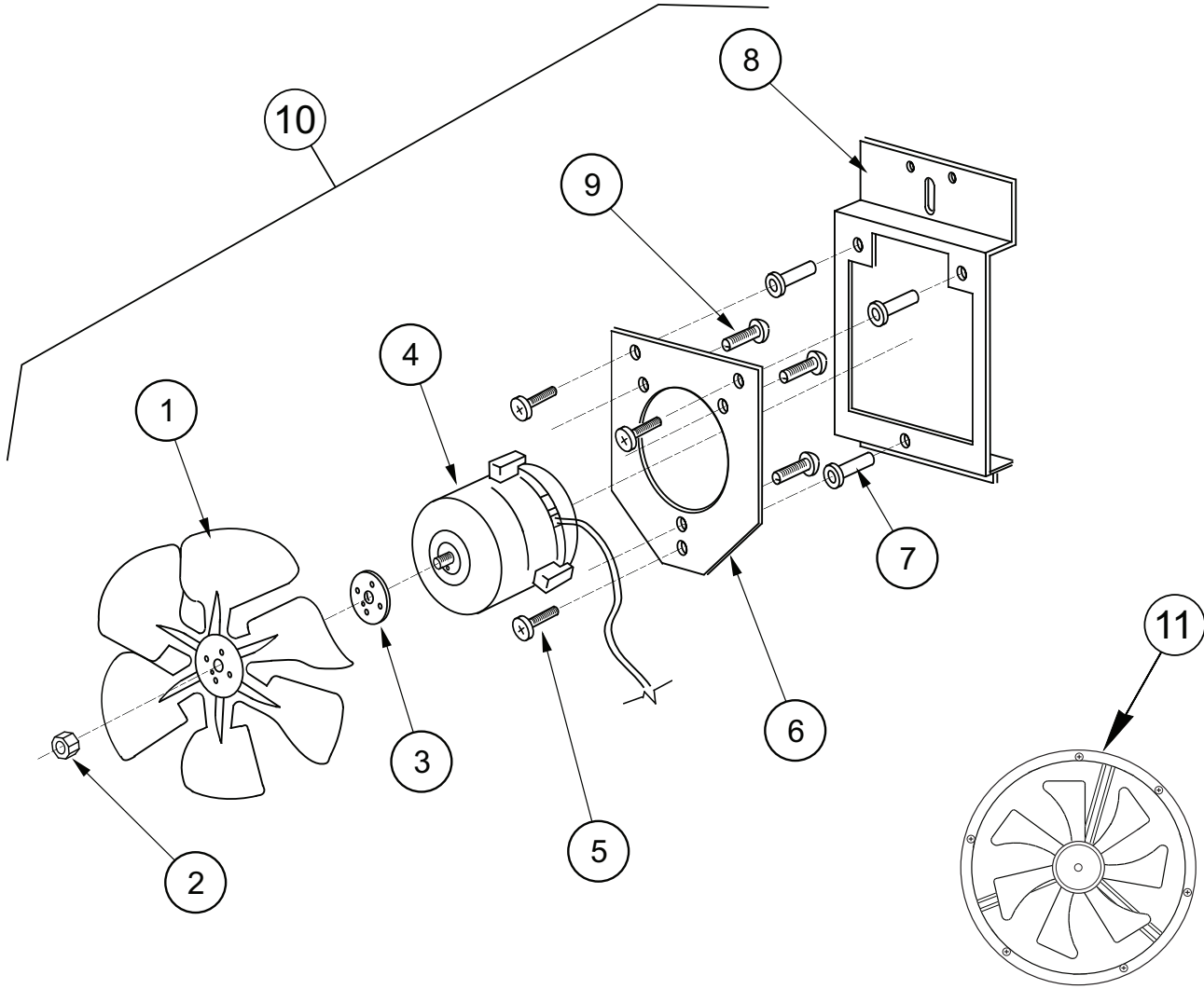

## Section 7. Exploded Views and Part Numbers

---

### Evaporator Fan Motor Assembly

ITEM NUMBER	DESCRIPTION	PART NUMBER
1	Fan Blade, Counterclockwise (newer).....	810077
	- Clockwise (older).....	810045
2	Nut, 1/4-20.....	905002
3	Silencer.....	939037
4	Motor, 35 W / 115 VAC CCW.....	839033
5	Machine Screw, #8-32 x 1/2.....	901038
6	Fan Plate.....	010058
7	Well Nut, #8-32.....	905026
8	Fan Mounting Bracket.....	231005
9	Sems Screw, #8-32 x 3/8.....	901011
10	Evaporator Fan Motor Assembly CCW (includes Items 1-9).....	303121
11	Energy Efficient Evaporator Fan Assembly (200211 and after).....	231060

## Section 7. Exploded Views and Part Numbers

### Airflow Vend Mechanism Assembly (200422XX00001 and after)

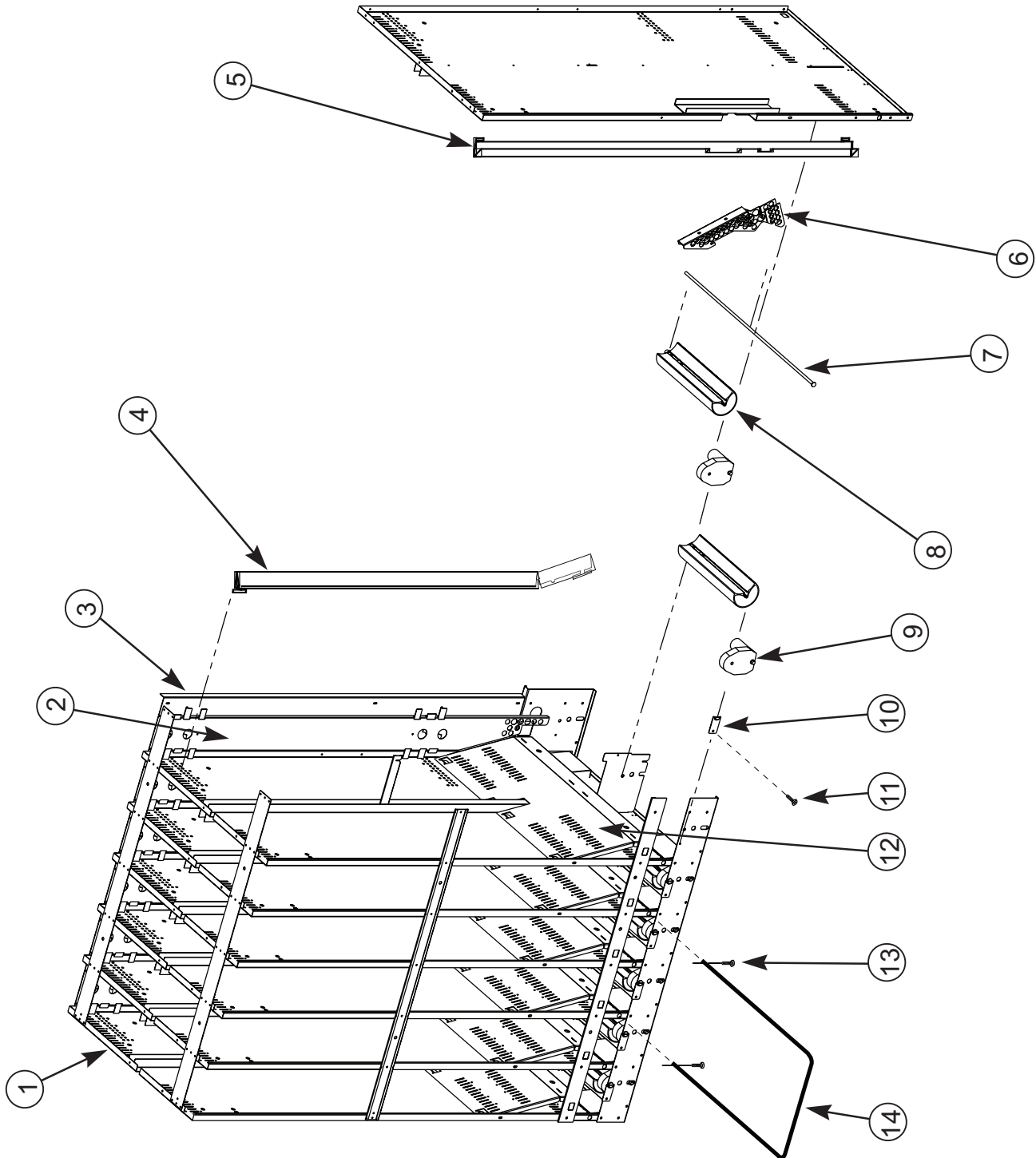

## Section 7. Exploded Views and Part Numbers

---

### Airflow Vend Mechanism Assembly (200422XX00001 and after)

ITEM NUMBER	DESCRIPTION	PART NUMBER
1	Vend Mechanism Assembly, Airflow, 79" Vender, 12 column.....	261710
	- 72" Vender, 12 column.....	262740
	- 72" Vender, 10 column.....	264730
2	Backspacer Assembly, Airflow, 79" Vender.....	261720
	- 72" Vender.....	262750
3	Backplate, Airflow Stack, 79" Vender.....	261711
	- 72" Wide Vender.....	332704
	- 72" Narrow Vender.....	264732
4	Product Retainer, Left, 79" Vender.....	810093
	- 72" Vender.....	810095
5	Product Retainer, Right, 79" Vender.....	810092
	- 72" Vender.....	810094
6	Funnel Angle, Airflow.....	810243
7	Rotor Rod.....	803035
8	Rotor.....	813027
9	Vend Motor.....	839031
10	Rod Retainer.....	256714
11	Screw, #8-32 x 3/8".....	901011
12	Product Funnel.....	332702
13	Self Drilling Screw.....	902004
	- Hitch Pin Clip ( <i>some venders may have pins</i> ).....	906023
14	Case Support.....	811026
•	Front Rotor Bearing.....	915156
•	Rear Rotor Bearing.....	915222
•	Front Rotor Assembly (incl. rotor, front rotor bearing, and motor).....	332730
•	Rear Rotor Assembly (incl. rotor, rear rotor bearing, and motor).....	332740
•	Anti-bridging Spacer, Front.....	815392
•	Anti-bridging Spacer, Rear.....	815393
•	Anti-friction sheet.....	915197
•	Rubber Retainer Strip.....	915217
•	Rear Can Retainer (anti-tilt Spring).....	810054

# Section 7. Exploded Views and Part Numbers

## Vend Mechanism Assembly (prior to 200422XX00001)

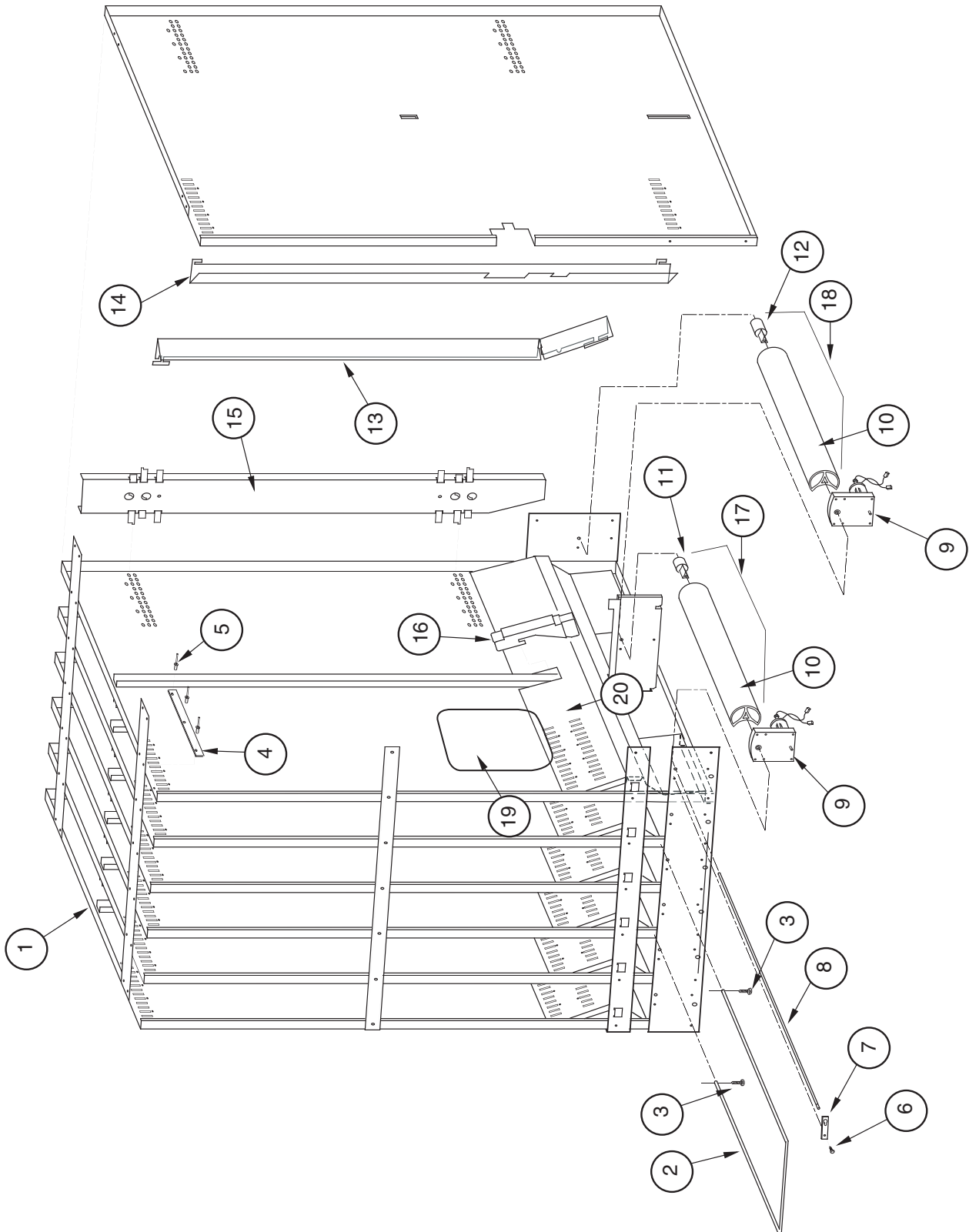

## Section 7. Exploded Views and Part Numbers

---

### Vend Mechanism Assembly (prior to 200422XX00001)

ITEM NUMBER	DESCRIPTION	PART NUMBER
1	Vend Mechanism Assembly, 12 Col. 79" Vender .....	256710
	Vend Mechanism Assembly, 12 Col. 72" Vender .....	262720
	Vend Mechanism Assembly, 10 Col. 79" Vender .....	258710
	Vend Mechanism Assembly, 10 Col. 72" Vender .....	264710
2	Case Support, Wide.....	811026
3	Self Drilling Screw.....	902004
	Hitch Pin Clip ( <i>some venders may have pins</i> ).....	906023
4	Rubber Strip.....	915199
5	1/8" Rivet .....	908002
6	Screw, #8-32x3/8" .....	901011
7	Rod Retainer.....	256714
8	Rotor Rod .....	803035
9	Vend Motor, Merlin IV (Black).....	839031
	-1618 and Before (White) .....	839029
10	Rotor, Merlin IV .....	815305
11	Front Rotor Bearing .....	915156
12	Rear Rotor Bearing.....	915222
13	Product Retainer, Left (79" Vender).....	810093
	Product Retainer, Left (72" Vender).....	810095
14	Product Retainer, Right (79" Vender).....	810092
	Product Retainer, Right (72" Vender).....	810094
15	Backspacer Assembly (79" Vender).....	256730
	Backspacer Assembly (72" Vender).....	257730
16	Funnel Angle.....	256719
17	Rotor Assembly, Front Column .....	256740
18	Rotor Assembly, Rear Column.....	256750
19	Anti-friction Sheet .....	915197
20	Can Funnel .....	256712
•	Rear Can Retainer (anti-tilt Spring) .....	256717

# Section 7. Exploded Views and Part Numbers

## Miscellaneous Assemblies

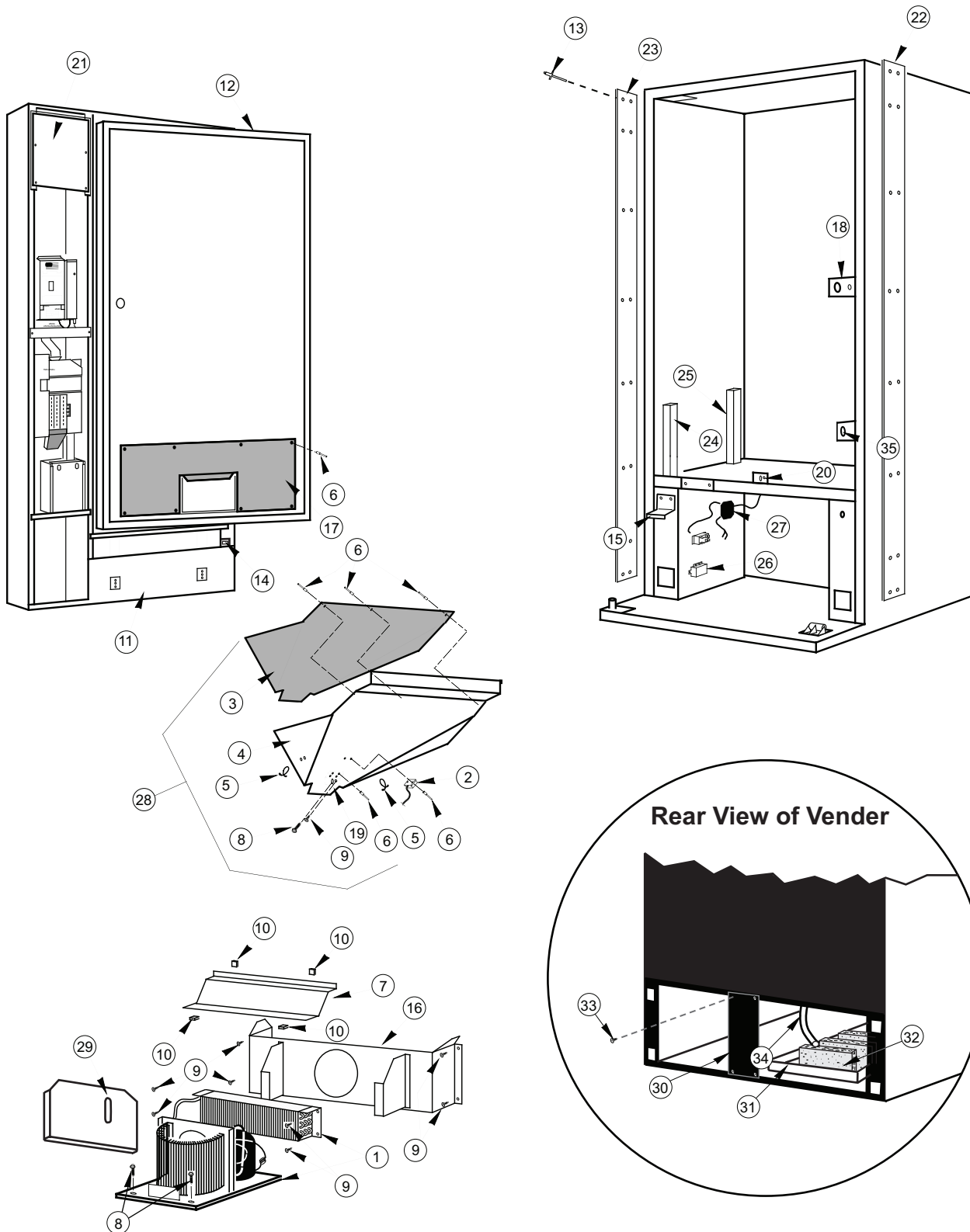

# Section 7. Exploded Views and Part Numbers

## Miscellaneous Assemblies

ITEM NUMBER	DESCRIPTION	PART NUMBER
1	Refrigeration System .....	256420
2	Delivery Chute Sensor, Piezo .....	210121
	- Impact Sensor ( <i>older style</i> ) .....	836004
3	Delivery Chute Liner, Wide Vender .....	815262
	-Narrow Vender .....	815270
4	Delivery Chute, Wide Vender .....	256005
	- Narrow Vender .....	258001
5	Tension Clips .....	916059
6	Rivets, 1/8" .....	908004
7	Evaporator Cover, Energy Efficient Fan, 200422 and after .....	256033
	- Energy Efficient Fan, prior to 200422 .....	256025
	- 35W Evaporator Fan Motor Assembly .....	256004
8	Self Tapping Screw, 1/4-20x1" .....	901003
9	Self Drilling Screw, #8x1/2" .....	902004
10	"U" Clips .....	906007
11	Pepsi Door Weld Assembly, 10 Sel. 79" Wide Vender (prior to 1533) .....	227510
	- Cold Drink Door W/A, 10 Sel. 79" W.V. (prior to 1533) .....	216510
	- PC/CD Door W/A 1533 and after 79" WV .....	273582
	- PC/CD Door W/A 1533 and after 72" WV .....	274581
	- PC/CD Door W/A 1533 and after 72" NV .....	264590
12	Inner Door Assembly 79" Wide Vender .....	261640
	Inner Door Assembly 79" Narrow Vender .....	258630
	Inner Door Assembly 72" Wide Vender (Dr Pepper Vision IV) .....	272640
	Inner Door Assembly 72" Narrow Vender .....	264630
13	Pop Rivet .....	908018
14	Door Switch (1521 and after) .....	835019
15	Door Switch Actuator .....	231009
16	Evaporator Fan Housing, Wide Vender .....	256080
	-Narrow Vender .....	258070
17	Inner Door Cover Assembly, Wide Vender .....	815259
18	Latch Strike Assembly .....	281010
19	Bracket, Chute Locator .....	141014
20	Can Chute Tie Bracket .....	010017
21	PC Board Cover .....	141903
22	Right Cabinet Vandal Panel 79" (specify color) .....	012122
	- 72" (specify color) .....	011002
23	Left Cabinet Vandal Panel 79" (specify color) .....	010022
	- 72" (specify color) .....	011001
24	Mech. Support, W/A .....	256013
25	Mech. Support, 3 Deep .....	058001
26	In-Line Filter Assembly .....	011124
27	Main Wiring Harness, inside cabinet, 200714 and after .....	842424
	- To wall outlet, 200714 and after .....	842628
	- Entire Harness, 200713 and before .....	842063
28	Can Chute Assembly, Wide Vender ( <i>does not include chute sensor</i> ) .....	256070
	- Narrow Vender ( <i>does not include chute sensor</i> ) .....	258001
29	Condenser Baffle .....	010403
	Condenser Baffle (Narrow M-IV) .....	258401
30	Rear Baffle .....	010037
31	Condensate Pan .....	815368
32	Sponge .....	815037
33	Self Drilling Screw .....	902004
34	Drain Tube .....	815134
35	Door Switch (Before P.O. 1521) .....	835003
•	Temperature Sensor Mounting Bracket, 200722 and after ( <i>below chute assembly</i> ) .....	286002
•	Caster Kit Assembly, Heavy Duty M-IV .....	256130
•	Mesh Cabinet Back (Wide) .....	141001
	-Narrow .....	258004
•	Steel Cabinet Back (Wide) .....	010215
	-Steel Narrow .....	258005
•	Drain Hose Clip .....	906025

# Section 7. Exploded Views and Part Numbers

## Door Assembly, Front

Cold Drink 1533 & before

W/A 10 Sel. 79" W.....	216510
- 8 Sel N.....	268510
Left Side Trim 79" W.....	032505
- 72".....	019507
Top Trim W.....	032504
- Narrow.....	044513
Bottom Trim Wide.....	032504
- Narrow.....	044514
Right Side Trim 79" Wide.....	032506
- 72".....	019508

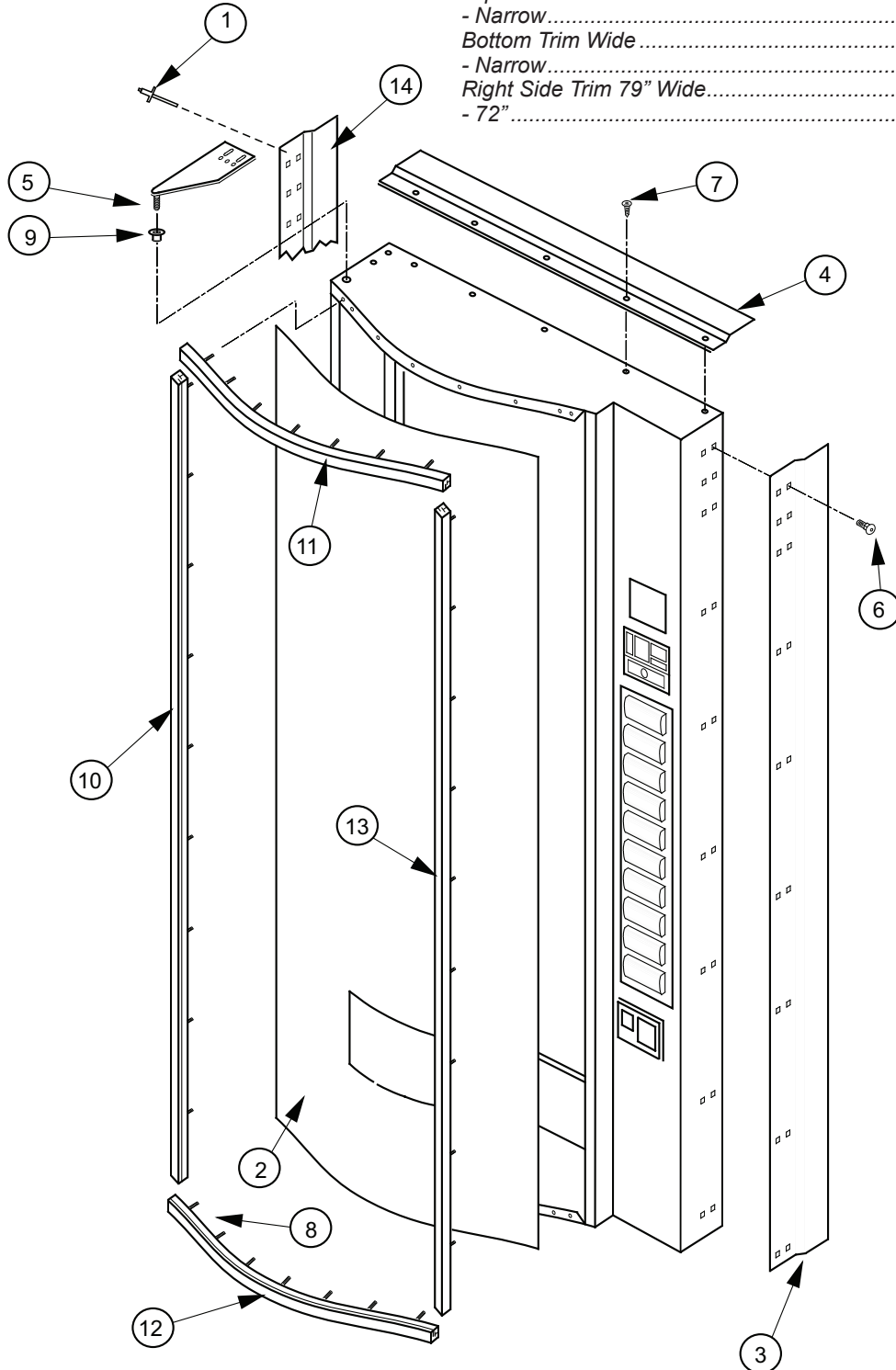

## Section 7. Exploded Views and Part Numbers

---

### Door Assembly, Front

ITEM NUMBER	DESCRIPTION	PART NUMBER
1	Pop Rivet .....	908018
2	Sign.....	SEE NOTE
3	Right Vandal Panel 79" (Specify color) .....	010519
	Right Vandal Panel 72" (Specify color) .....	011501
4	Rain Guard, Wide Venders .....	258504
5	Top Door Hinge.....	810002
6	Carriage Bolt, 1/4-20x1/2" .....	901007
7	Self Drilling Screw, #8x1/2" .....	902004
8	"T"-Screw 8-32 .....	901001
9	Top Door Bushing .....	803003
10	Left Side Trim 79" Wide Vender (after 1533) .....	141553
	Left Side Trim 72" Wide Vender (after 1533) .....	142502
11	Top Trim Wide Vender (after 1533).....	012553
	Top Trim Narrow Vender .....	040807
12	Bottom Trim Wide Vender (after 1533) .....	012553
	Top/Bottom Trim (M4) Narrow Vender .....	040811
13	Right Side Trim 79" Wide Vender (after 1533).....	012554
	Right Side Trim 72" Wide Vender (after 1533).....	013507
	Right Side Trim 72" Narrow Vender .....	019508
14	Left Vandal Panel, 79" (Specify color) .....	141002
	Left Vandal Panel, 72" (Specify color) .....	142001
•	Christmas Tree .....	916009

**NOTE:** There are various parts. Please specify model and serial number at the time of order

# Section 7. Exploded Views and Part Numbers

## Door Assembly, Rear

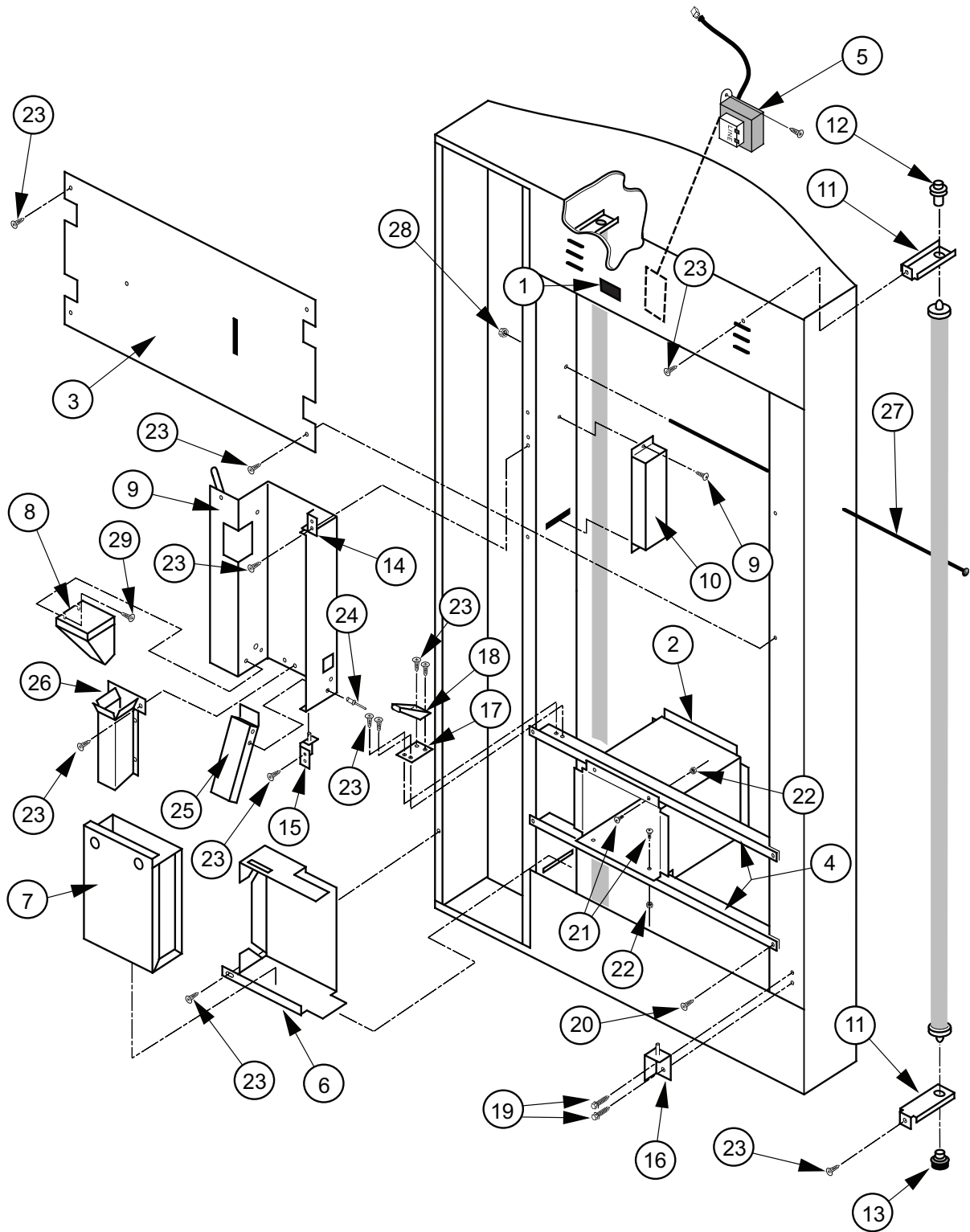

## Section 7. Exploded Views and Part Numbers

---

### Door Assembly, Rear

ITEM NUMBER	DESCRIPTION	PART NUMBER
1	Fusebox Assembly.....	842219
2	Port Body Welded Assembly (Narrow Port).....	273510
	Port Body Welded Assembly (Wide Port).....	303510
3	Lamp Guard, Wide Venders .....	012514
	Lamp Guard, Narrow Vender, Merlin IV.....	258505
4	Port Brace, Wide Venders .....	010515
	Port Brace, Narrow Vender, Merlin IV.....	258506
5	Transformer Assembly .....	842147
6	Coin Box Housing (1405 & after).....	273540
7	Coin Box Welded Assembly (1405 & after).....	010580
8	Coin Hopper (wide port).....	303502
9	Changer Door .....	010544
10	Ballast Assembly, 72" / 79", CDC, T8 Lighting.....	262598
	- 79" Wide Vender, Non CDC, T12 .....	012940
	- 72", Non CDC, T12.....	013920
	- 79", CDC, T12 .....	198920
	- 72", CDC, T12 .....	195910
11	Lamp Bracket, T8 Lighting, all except top left.....	010517
	- T8, top left.....	261517
	- T12, all.....	010517
12	Top Lampholder, T8 .....	842512
	- T12 .....	842003
13	Bottom Lampholder, T8 .....	842513
	- T12 .....	842004
14	Changer Door Hinge Assembly, Top.....	010570
15	Changer Door Hinge Assembly, Bottom .....	010560
16	Bottom Inner Door Hinge.....	010550
17	Latch Roller Bracket .....	010516
18	Burst Open Latch Strike.....	812003
19	Self Tapping Screw, 1/4-20x1".....	901003
20	Self Drilling Screw, #8-32.....	902004
21	Carriage Bolt, 1/4-20x1/2".....	901007
22	Keps Nut, 1/4-20.....	905002
23	Sems Screw, #8-32x3/8".....	901011
24	Pop Rivet, 1/8".....	908004
25	Bottom Coin Chute Assembly (To Coin Box), Wide Port .....	303501
	- Narrow port.....	012593
26	Hopper Chute Assembly (To Coin Cup).....	012538
27	Door Rod .....	811001
28	Elastic Stop Nut .....	905004
29	Screw #8-32x1/2" with washers.....	901006



## Section 7. Exploded Views and Part Numbers

---

### Select Panel Assembly, Rear

ITEM NUMBER	DESCRIPTION	PART NUMBER
1	Coin Return Cup (Steel) .....	012595
2	PC Board Spacer.....	916027
3	Control Board.....	836101
4	Self Drilling Screw, #8-18x1/2".....	902004
5	Control Board Cover .....	141903
6	Control Panel Welded Assembly, 10 Select.....	017530
	Control Panel Welded Assembly, 8 Select.....	012510
7	Keps Nut, #8-32.....	905001
8	Select Switch Harness.....	SEE NOTE
9	Panel Strap (optional).....	010531
10	Screw.....	901041
11	Spring Shield .....	815164
12	Switch (large).....	835012
13	Switch Spacer.....	815018
14	Keps Nut.....	905018
15	Button Assembly .....	815025
16	Transformer Assembly.....	842147
17	Transformer Cover.....	010063
18	Self Tapping Screw, #8-32x3/8".....	901002
19	Ballast, Slimline .....	838002
•	Splash Guard (protects selection switches).....	815303

**NOTE:** There are various parts. Please specify model and serial number at the time of order.

## Section 7. Exploded Views and Part Numbers

### RVMC/RVCD Vandal Resistant Door (CDC) Front

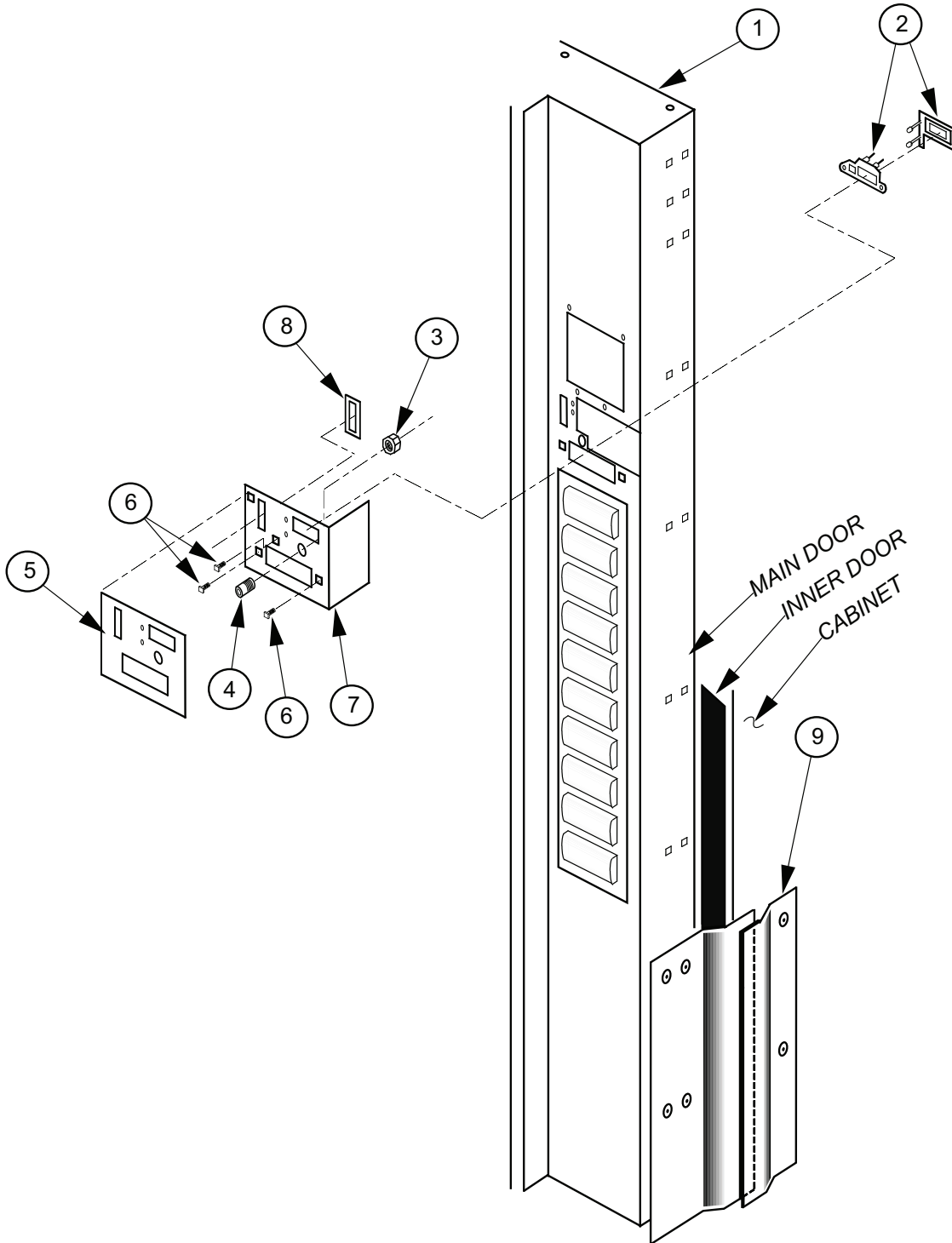

## Section 7. Exploded Views and Part Numbers

---

### RVMC/RVCD Vandal Resistant Door (CDC) Front

ITEM NUMBER	DESCRIPTION	PART NUMBER
1	C.D.C. Door Weld Assembly 79" Wide* UHR .....	198522
	C.D.C. Door Weld Assembly 72" Wide* UHR .....	195536
	-79" Wide Cold Drink* (1533 & before) .....	229510
	-72" Wide Cold Drink* (1533 & before) .....	230510
2	L.E.D. Assembly .....	010593
3	Hex Jam Nut 9/16-18 .....	905019
4	Bushing (for coin return button) .....	803030
5	Security Plate Decal (Electronic, CDC) .....	845530
6	"T" Screw 1/4-20x1" .....	901037
7	Security Plate Weld Assembly (CDC Only) .....	195510
8	Coin Plate .....	141516
9	Vandal Panel Cover 79" .....	171101
	Vandal Panel Cover 72" .....	172001

## Section 7. Exploded Views and Part Numbers

### RVMC/RVCD Vandal Resistant Door (CDC) Rear

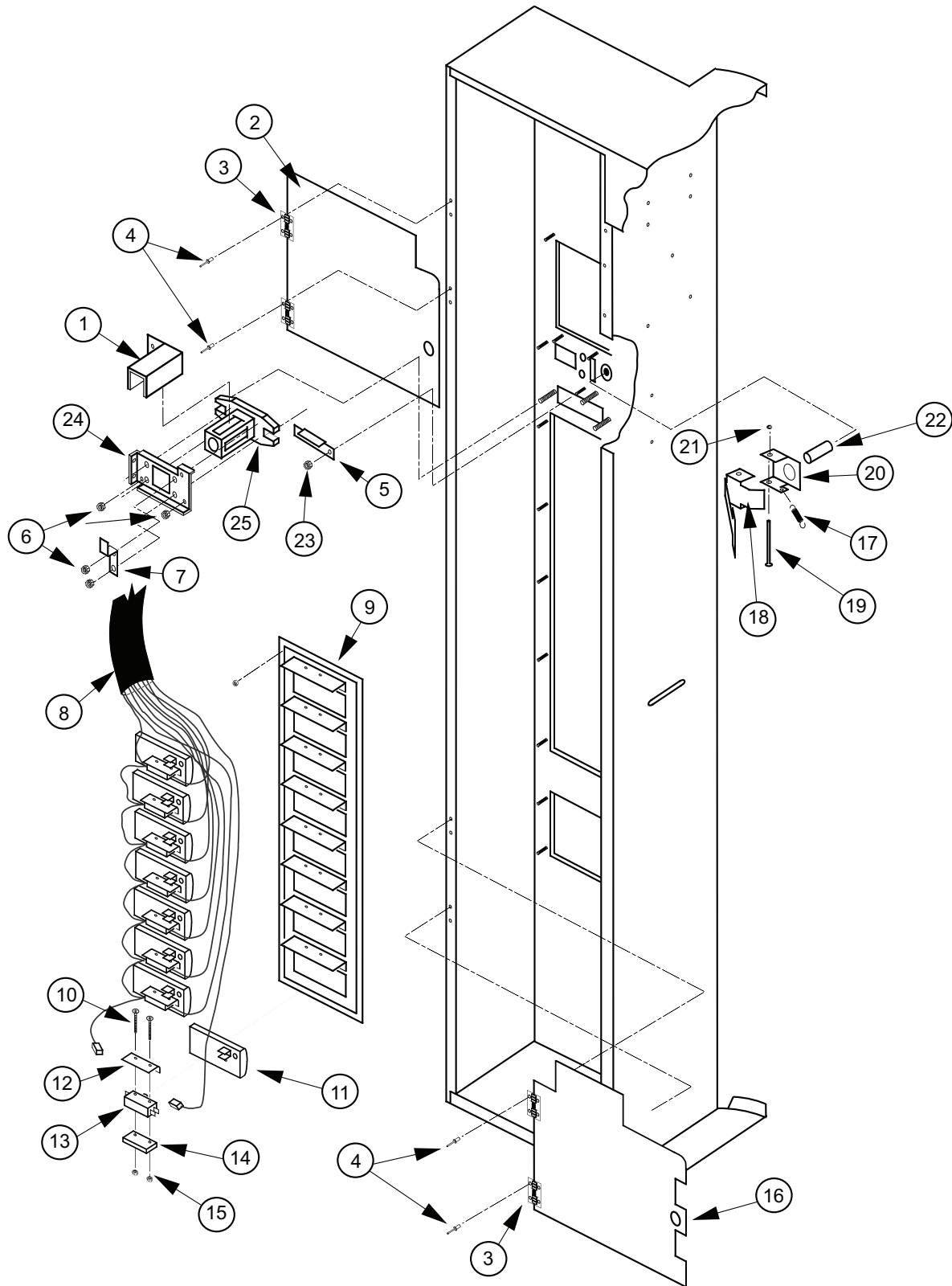

## Section 7. Exploded Views and Part Numbers

---

### RVMC/RVCD Vandal Resistant Door (CDC) Rear

ITEM NUMBER	DESCRIPTION	PART NUMBER
1	Lock Cylinder Cover .....	161532
2	Validator Security Door .....	141521
3	Spring Hinge (for Security Doors).....	912156
4	Pop Rivet 1/8" .....	908004
5	Coin Ramp.....	141508
6	Nut 1/4-20 .....	905002
7	Lever Stop .....	141514
8	Select Switch Harness.....	842190
9	Button Panel Weld Assembly-10 select .....	017530
	Button Panel Weld Assembly-8 select .....	012510
10	Screw.....	901041
11	Button Assembly .....	815025
12	Spring Shield .....	815164
13	Switch, Large .....	835012
14	Switch Spacer.....	815018
15	Nut .....	905018
16	Cash Box Guard (Security Door).....	011147
17	Coin Return Spring .....	914023
18	Button Lever (Coin Return Lever).....	161509
19	Roller Pin (5/32").....	811002
20	Hinge, Button Lever .....	161508
21	Retaining Ring (for 5/32" Diameter Rod) .....	906005
22	Button, Coin Return Lever .....	803031
23	Nut #8-32 .....	905001
24	T-Handle Brace.....	141513
25	T-Handle Housing .....	812190
•	Coin Return Lever Assembly non-CDC .....	141524

\* Denotes a color must be specified.

# Section 7. Exploded Views and Part Numbers

## RVMC/RVCD Center Door Changer Vault

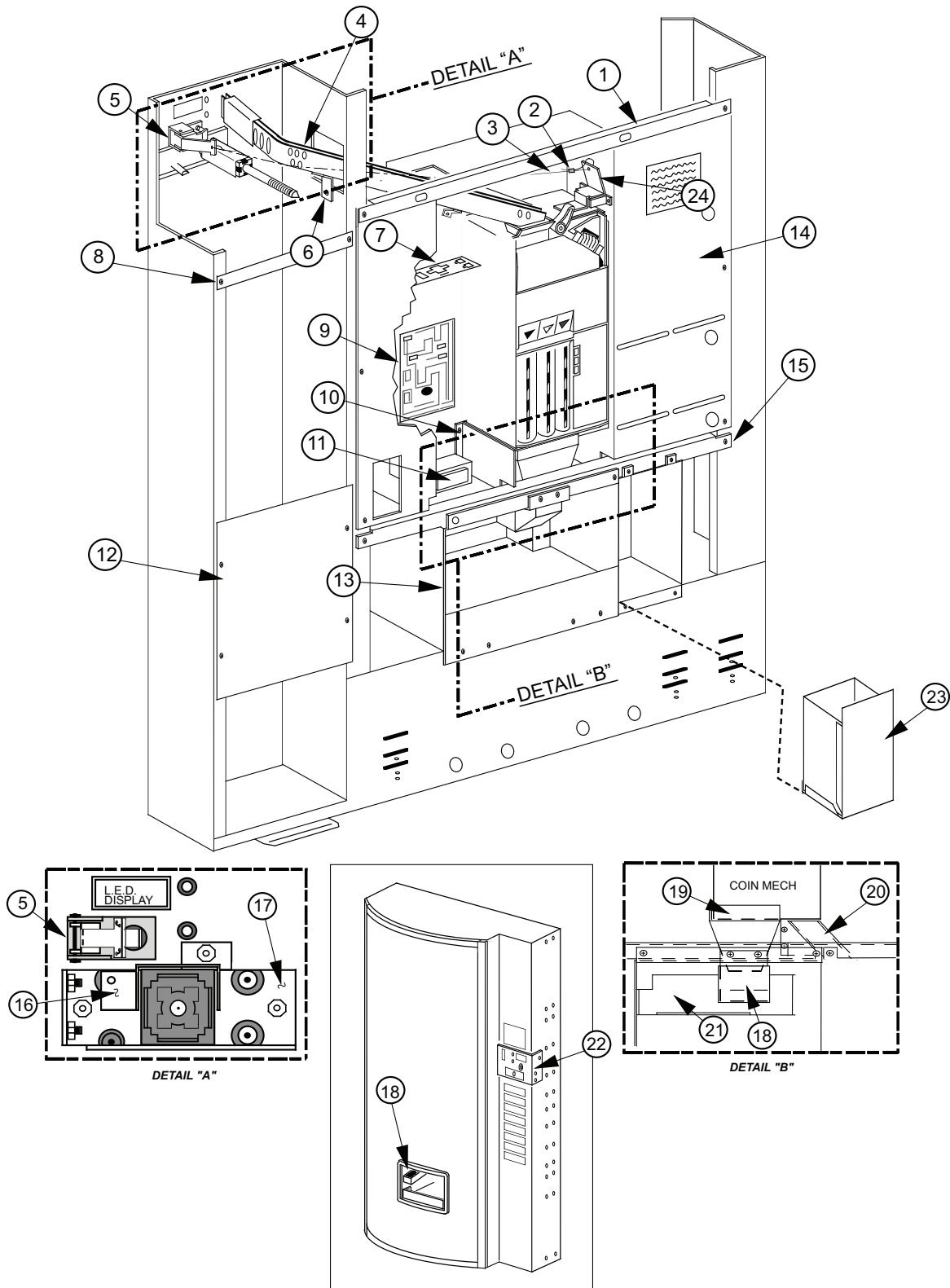

## Section 7. Exploded Views and Part Numbers

---

### RVMC/RVCD Center Door Changer Vault

ITEM NUMBER	DESCRIPTION	PART NUMBER
1	Changer Vault Brace.....	161518
2	Cable Sleeve (At Each End Of Cable) .....	906015
3	Cable .....	911032
4	Coin Chute Assembly / CDC Wide Vender .....	161590
5	Button Lever Assembly (Coin Return Lever) CDC (see detail "A") .....	161593
	-Non CDC .....	141524
6	Coin Chute Bracket 79.5" .....	161527
	- 72" .....	162502
7	Changer Plug Bracket.....	010561
8	Panel Strap .....	010531
9	Control Board.....	836134
10	Hopper Mounting Bracket.....	161515
11	Transformer Assembly, MIV .....	842147
	Merlin IV Harness, Transformer and Fuse to Board .....	842210
	Fuse, 3.0 .....	942111
12	Select Panel Plate .....	161512
13	Port Body Welded Assembly- WP .....	303510
14	Changer Vault Welded Assembly - WP.....	303506
15	Port Brace Welded Assembly .....	010515
16	Lock Cylinder Cover (see detail "A") .....	161532
17	T-Handle Brace (see detail "A") .....	141513
18	Coin Cup, CDC .....	231505
19	Coin Hopper - WP.....	303502
20	Coin Box Coin Chute - WP .....	303501
21	Anti-Theft Plate .....	161504
	Anti-Theft Plate, CDC, Wide .....	305501
	Anti-Theft Plate, Non-CDC, Wide .....	303503
22	Security Plate Welded Assembly .....	195510
23	Coin Box Welded Assembly.....	161570
	-Plastic Coin Box .....	815347
•	Coin Insert Assembly .....	195560
•	Changer Vault Door (Not Shown), Optional.....	161534
•	Board Cover (CDC) .....	195518
•	Coin Deflector .....	161526

## Section 7. Exploded Views and Part Numbers

### Port Assembly, Dr Pepper Vision 4

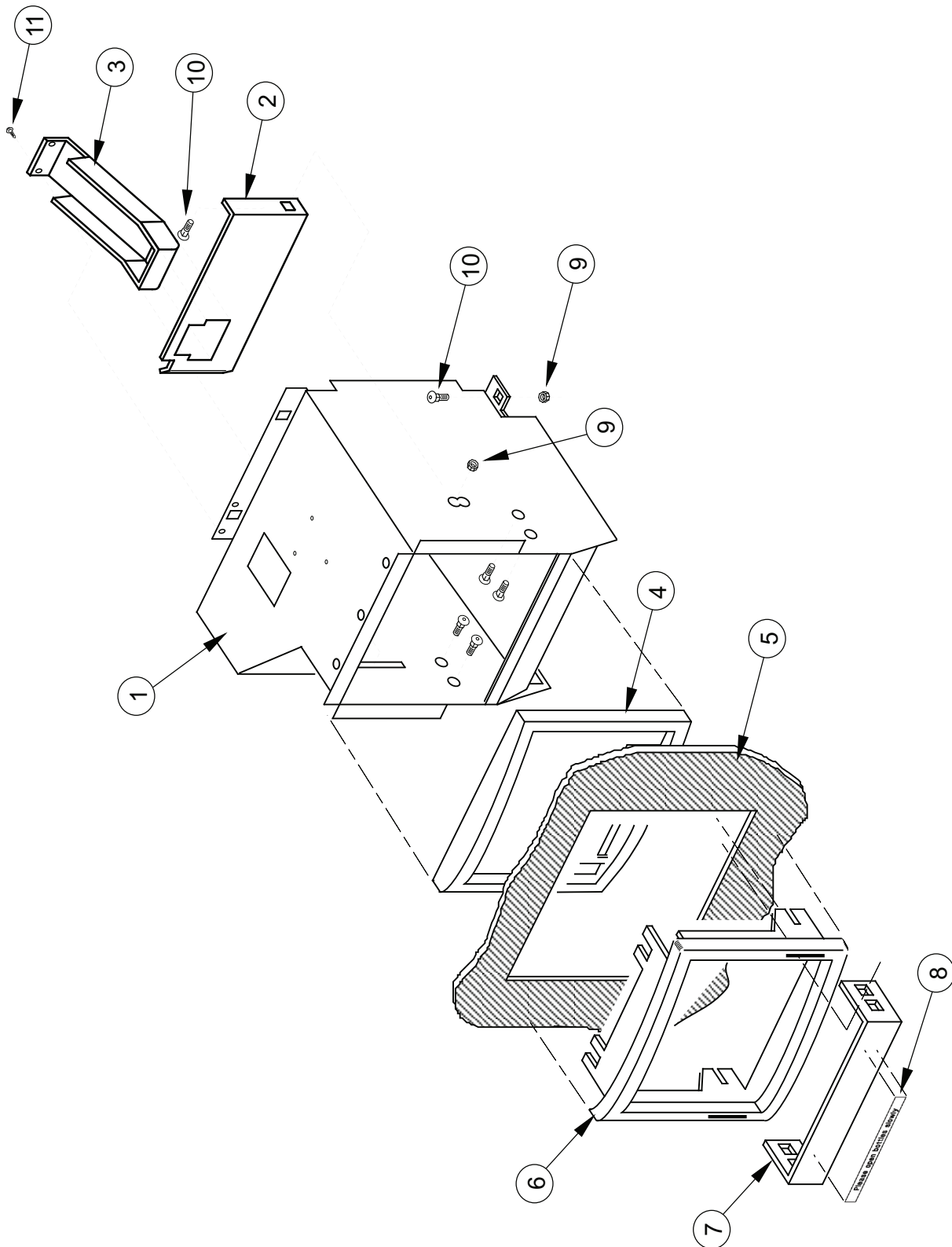

## Section 7. Exploded Views and Part Numbers

---

### Port Assembly, Dr Pepper Vision 4

ITEM NUMBER	DESCRIPTION	PART NUMBER
1	Port Body Welded Assembly / CDC - WP.....	303510
2	Anti-Theft Plate / CDC - WP.....	303503
3	Coin Cup / CDC.....	273570
4	Port Spacer.....	815020
5	Sign.....	SEE NOTE
6	Port Trim - WP.....	815249
7	Can Stop.....	273508
8	Anti-Foaming Label.....	931355
9	Nut 1/4-20.....	905002
10	Carriage Bolt 1/4-20x1/2".....	901007
11	Screw #8-32x3/8".....	901011

**NOTE:** There are various parts. Please specify model and serial number at the time of order.

# Section 7. Exploded Views and Part Numbers

## Door Assembly Front, Dr Pepper Vision 4

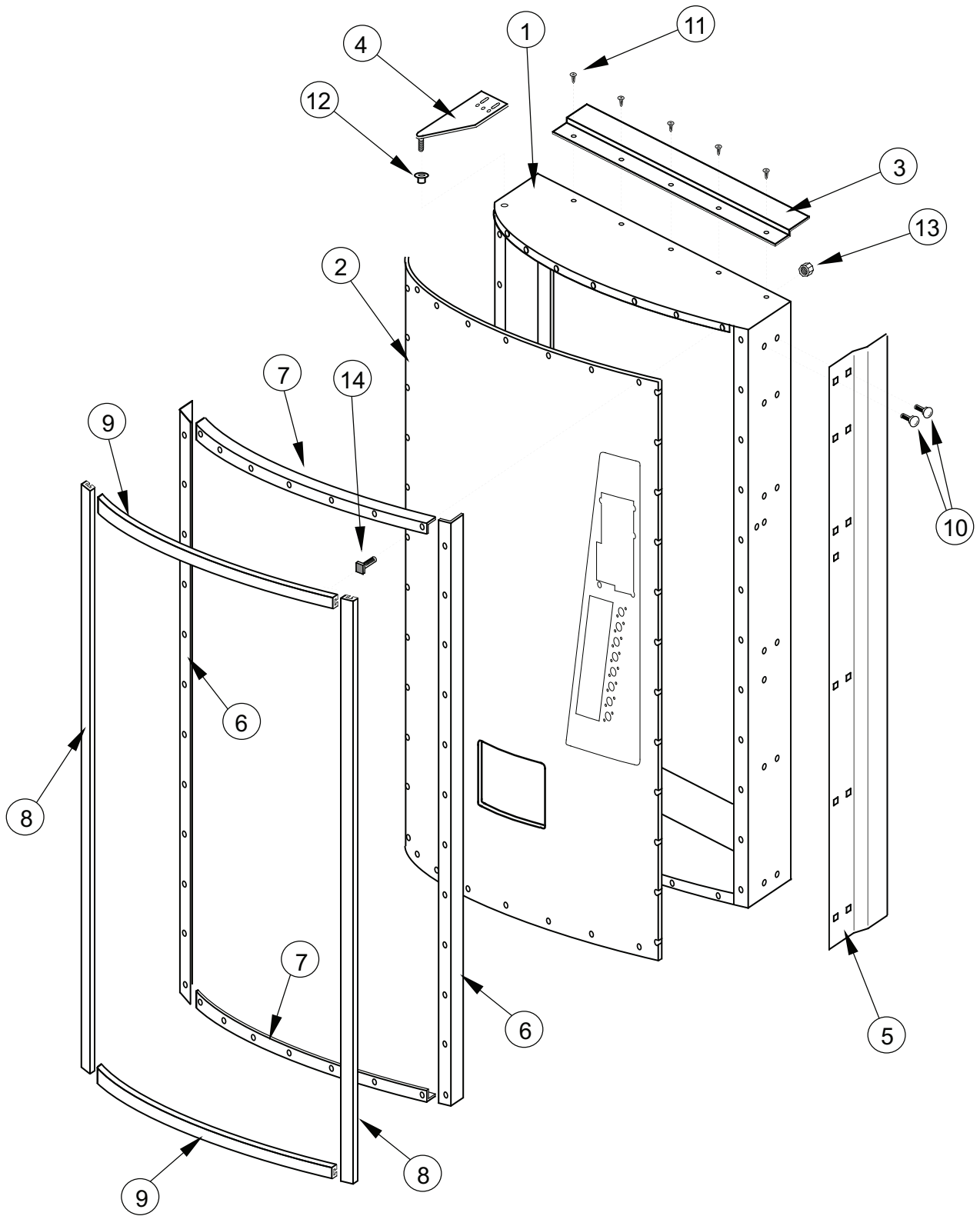

## Section 7. Exploded Views and Part Numbers

---

### Door Assembly Front, Dr Pepper Vision 4

ITEM NUMBER	DESCRIPTION	PART NUMBER
1	Main Door Welded Assembly / Vision 4 / CDC 79" .....	242537
	Main Door Welded Assembly / Vision 4 / CD. 72" .....	243550
2	Sign, Dr Pepper Vision 4 (Must Give # of Selections) .....	SEE NOTE
3	Rain Guard, Wide Venders .....	010518
4	Top Main Door Hinge .....	810002
5	Vandal Panel, Right (Door) 79" .....	010519
	Vandal Panel, Right (Door) 72" .....	011501
6	Metal Trim, Right & Left 79" .....	171507
7	Metal Trim, Top and Bottom .....	171502
8	Trim, Right and Left 79" .....	242526
9	Trim, Top and Bottom .....	242525
10	Carriage Bolt 1/4-20x1/2" .....	901007
11	Self Drilling Screw #8x1/2" .....	902004
12	Top Door Bushing .....	803003
13	Nut 1/4-20 .....	905002
14	T-Bolt 1/4-20x1" .....	901037

**NOTE:** There are various parts. Please specify model and serial number at the time of order.



## Section 7. Exploded Views and Part Numbers

---

### Door Assembly Rear, Dr Pepper Vision 4

ITEM NUMBER	DESCRIPTION	PART NUMBER
1	Main Door Welded Assembly / Vision 4 / CDC 79" .....	242537
	Main Door Welded Assembly / Vision 4 / CDC 72" .....	243550
2	Lamp Bracket.....	010517
3	Top Lampholder (Springloaded) .....	842003
4	Bottom Lampholder .....	842004
5	Ballast Assembly .....	231560
6	Self Tapping Screw 1/4-20x1" .....	901003
7	Screw #8-32x3/8".....	901011
8	Validator Vault Welded Assembly .....	242530
9	Button Bracket Welded Assembly - DP Vision 4.....	242550
10	Changer Vault Welded Assembly .....	161523
11	Port Body Welded Assembly / CDC - WP.....	303503
12	Validator Vault Brace 79" .....	242511
	Validator Vault Brace 72" .....	243501
13	Coin Box Welded Assembly, Vision 4 CDC .....	231550
14	Latch Roller Bracket .....	242512
15	Burst Open Latch Strike .....	812003
16	Bottom Inner Door Hinge.....	010550

# Section 7. Exploded Views and Part Numbers

## Coin Insert Assembly Front, Dr Pepper Vision 4

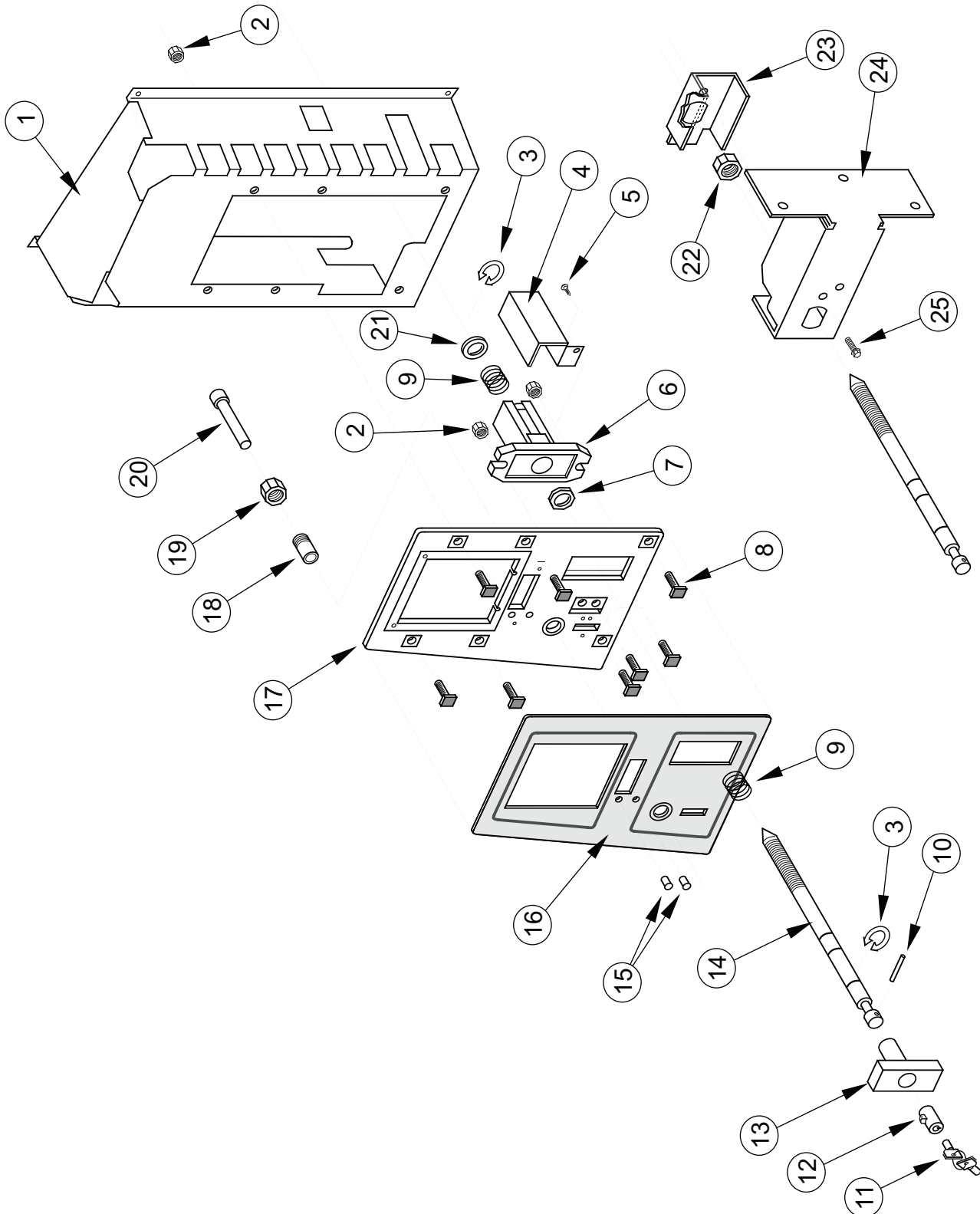

## Section 7. Exploded Views and Part Numbers

---

### Coin Insert Assembly Front, Dr Pepper Vision 4

ITEM NUMBER	DESCRIPTION	PART NUMBER
1	Validator Vault Welded Assembly .....	242530
2	Nut 1/4-20 .....	905002
3	Retaining Ring ("C" Clip).....	912157
4	Lock Cylinder Cover .....	161532
5	Self Tapping Screw #8-32x3/8" .....	901011
6	T-Handle Housing .....	812190
7	Brass Hex Washer .....	SEE NOTE #2
8	T-Bolt 1/4-20x1" .....	901037
9	Spring, T-Handle .....	SEE NOTE #2
10	Pin, T-Handle .....	912133
11	2 Keys.....	SEE NOTE #1
12	Lock .....	SEE NOTE #1
13	T-Handle Body.....	812134
14	T-Handle Stud.....	SEE NOTE #2
15	LED Lens .....	916032
16	Security Plate Decal / Dr Pepper Vision 4 .....	845765
17	Security Plate Welded Assembly .....	242520
18	Bushing, Button Coin Return .....	803030
19	Hex Jam Nut 9/16-18 UNF2A .....	905019
20	Button, Coin Return Lever .....	803031
21	Washer .....	SEE NOTE #2
22	Square Nut 3/4x1/2-13.....	905005
23	Nut Retainer.....	010028
24	Latch Strike Assy. ....	242031
25	Self Tapping Screw 1/4-20x1" .....	901003
•	T-Handle Assembly, Vision 4 .....	812277

**NOTE #1:** There are various parts. Please specify model and serial number at the time of order.

**NOTE #2:** This part is not available individually. It must be ordered as an assembly.

# Section 7. Exploded Views and Part Numbers

## CI Rear & Button Panel Assembly, Dr Pepper Vision 4

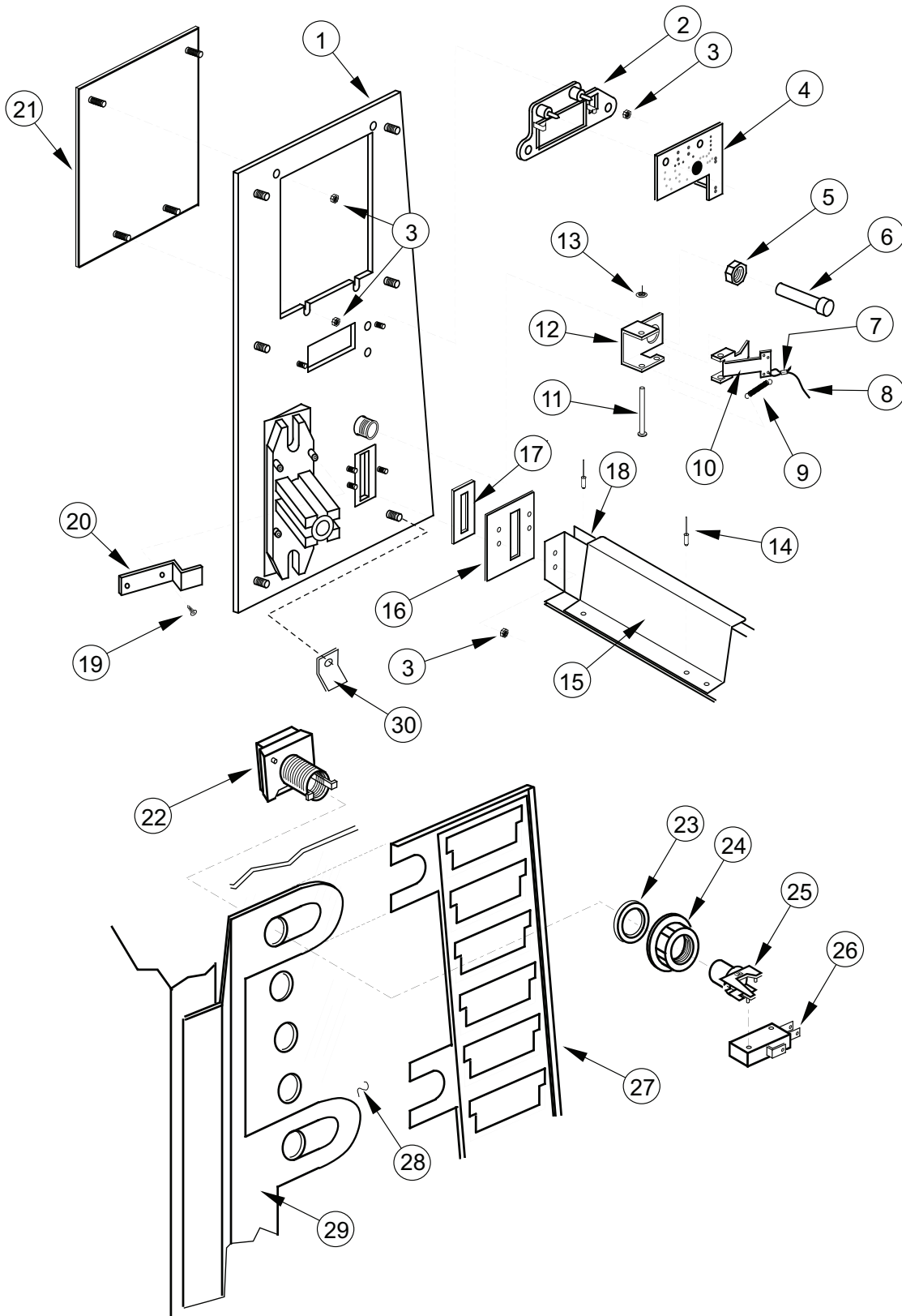

## Section 7. Exploded Views and Part Numbers

### CI Rear & Button Panel Assembly, Dr Pepper Vision 4

ITEM NUMBER	DESCRIPTION	PART NUMBER
1	Security Plate Welded Assembly .....	242520
2	LED Window .....	815121
3	Nut #8-32 .....	905001
4	LED Display .....	836012
5	Hex Jam Nut 9/16" - 18 UNF2A .....	905019
6	Button, Coin Return Lever .....	803031
7	Cable Sleeve .....	906015
8	3/64" Diameter Cable .....	911032
9	Coin Return Spring .....	914023
10	Button Lever .....	161509
11	Coin Return Pin .....	811024
12	Hinge .....	161508
13	5/32 Retainer Ring .....	906005
14	Pop Rivet 1/8 Aluminum .....	908004
15	Coin Chute Cover - DP .....	242517
16	Coin Slot Retainer .....	242513
17	Coin Plate .....	141516
18	Coin Chute Assembly (includes #15 & #14) .....	242570
19	Self Tapping Screw #8-32 x 3/8" .....	901011
20	Lever Stop - DP .....	242521
21	Validator Cover Assembly - DP .....	100504
22	Button Assembly - DP .....	810052
23	Washer, Select Button - DP (Part of Button Assembly) .....	915230
24	Nut, Select Button - DP (Part of Button Assembly) .....	915229
25	Switch Holder - DP (Part of Button Assembly) .....	915225
26	Switch, Miniature .....	835001
27	Flavor Card Strip Assembly - DP Vision 4 .....	815228
28	Sign, Dr Pepper Vision 4 (must give number of selections) .....	SEE NOTE
29	Button Bracket Welded Assembly .....	242550
30	Flavor Card Strap, DP .....	242536
•	Select Button Assembly, Complete (includes #22-#25) .....	242580
•	Button Lever Assembly (Includes #9-#13) .....	161594

**NOTE:** There are various parts. Please specify model and serial number at the time of order.

# Section 7. Exploded Views and Part Numbers

## Changer Vault Assembly, Dr Pepper Vision 4

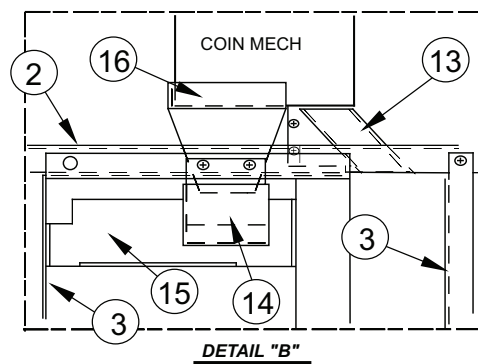
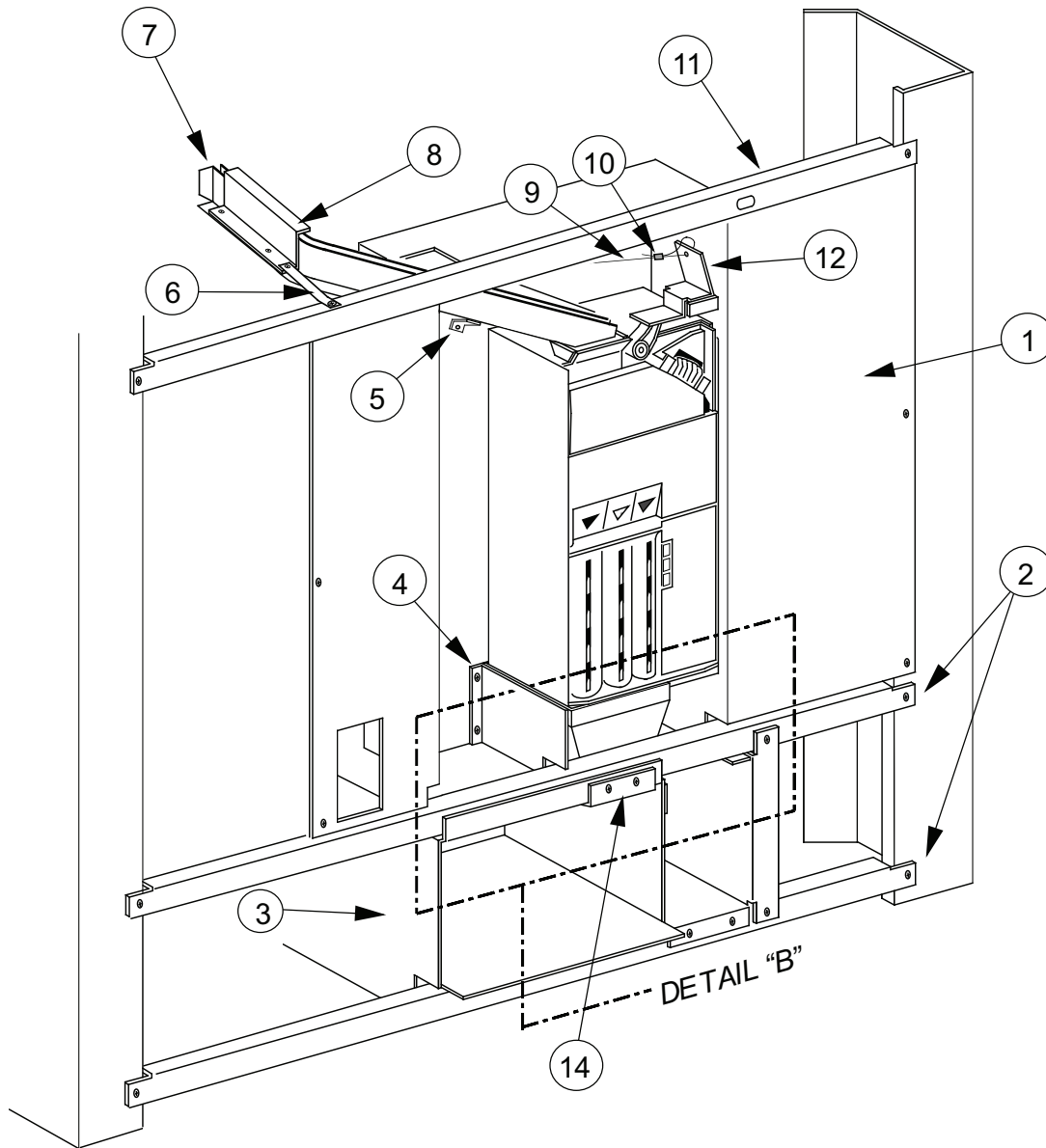

## Section 7. Exploded Views and Part Numbers

---

### Changer Vault Assembly, Dr Pepper Vision 4

ITEM NUMBER	DESCRIPTION	PART NUMBER
1	Changer Vault Welded Assembly - WP.....	303506
2	Port Brace, DP / CDC .....	242503
3	Port Body Welded Assembly / CDC - WP.....	303510
4	Hopper Mounting Bracket.....	161515
5	Support Bracket, Coin Chute / CDC .....	161537
6	Coin Chute Strap - DP.....	242516
7	Coin Chute Assembly (includes #5, #6 and #8).....	242570
8	Coin Chute Cover - DP .....	242517
9	3/64" Diameter Cable.....	911032
10	Cable Sleeve .....	906015
11	Changer Vault Brace.....	242504
12	Coin Return Lever Assembly .....	161593
13	Coin Box Coin Chute Welded Assembly.....	231519
14	Coin Cup - CDC.....	231505
15	Anti Theft Plate - CDC .....	305501
16	Coin Hopper - WP.....	303502
•	Coin Chute Bracket, 79" CDC (Not Shown).....	161527
•	Water Block, Coin Chute / DP - CDC (Not Shown).....	161536

# Section 7. Exploded Views and Part Numbers

## Flat Horizontal Display, Door Front

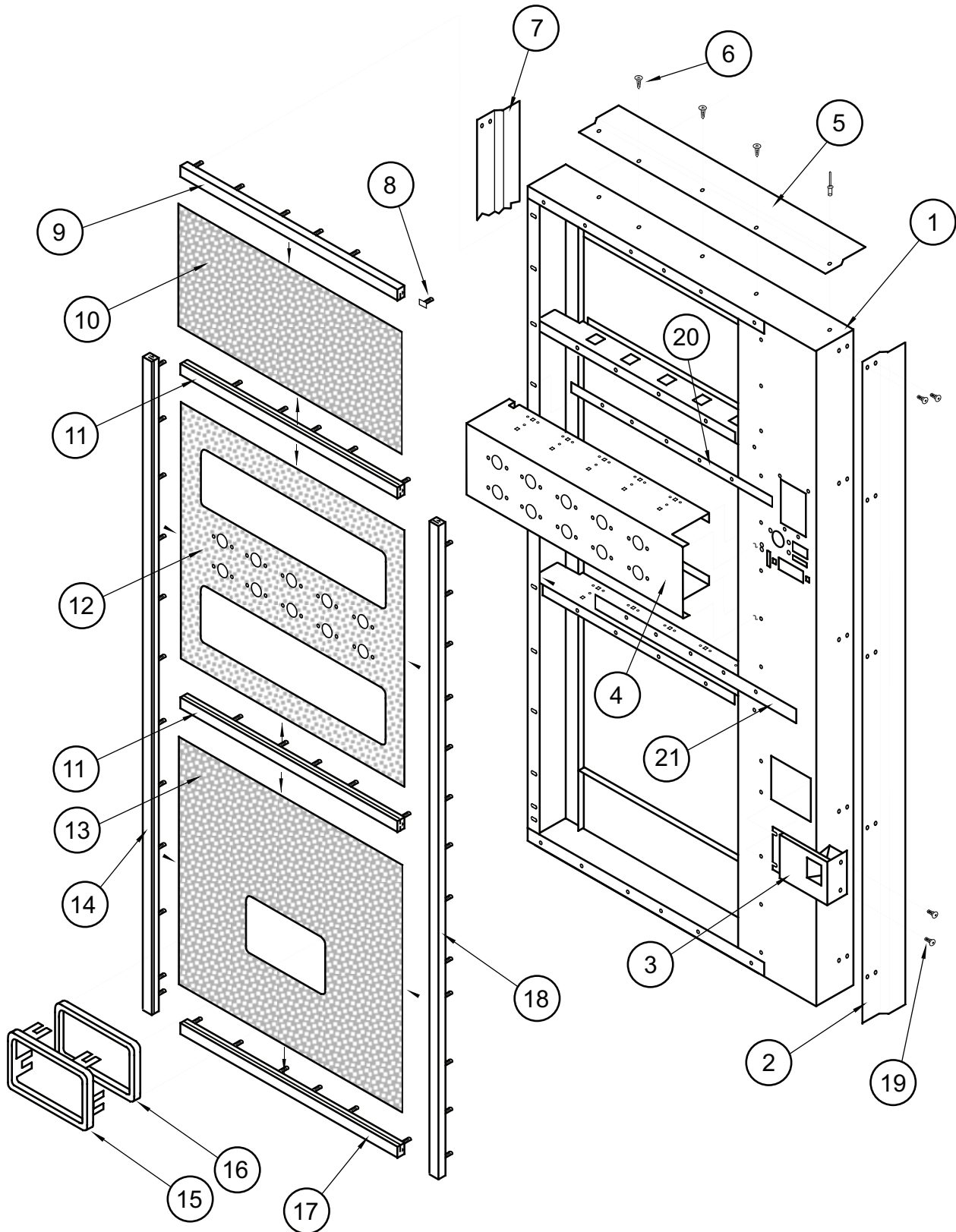

## Section 7. Exploded Views and Part Numbers

---

### Flat Horizontal Display, Door Front

ITEM NUMBER	DESCRIPTION	PART NUMBER
1	Door Welded Assembly - Flat Display - 72" .....	278552
2	Right Vandal Panel - 72" .....	011501
3	Coin Return Cup Welded Assembly .....	012595
4	Button Panel - Flat Display - 10 Select .....	278502
5	Rain Guard - Wide Venders .....	010518
6	Screw #8 x 1/2" .....	902004
7	Left Vandal Panel, 79" .....	141002
	Left Vandal Panel, 72" .....	142001
8	T-Screw #8-32 .....	901001
9	Trim, Top Side .....	032807
10	Sign, Top / Flat Display (Cold Drink Graphics) Black Graphics .....	845918
11	Trim, Center .....	278511
12	Sign, Center / Flat Display, Black Graphics .....	845919
13	Sign, Bottom / Flat Display, Black Graphics .....	845920
14	Trim, Left Side .....	019507
15	Port Trim, Wide Port .....	815249
16	Port Spacer, Wide Port .....	815248
17	Trim, Bottom Side .....	032806
18	Trim, Right Side .....	019508
19	Carriage Bolt 1/4-20 x 1/2" .....	901007
20	Price Label Strip - Top .....	278512
21	Price Label Strip - Bottom .....	278515

# Section 7. Exploded Views and Part Numbers

## Flat Horizontal Display, Door Rear

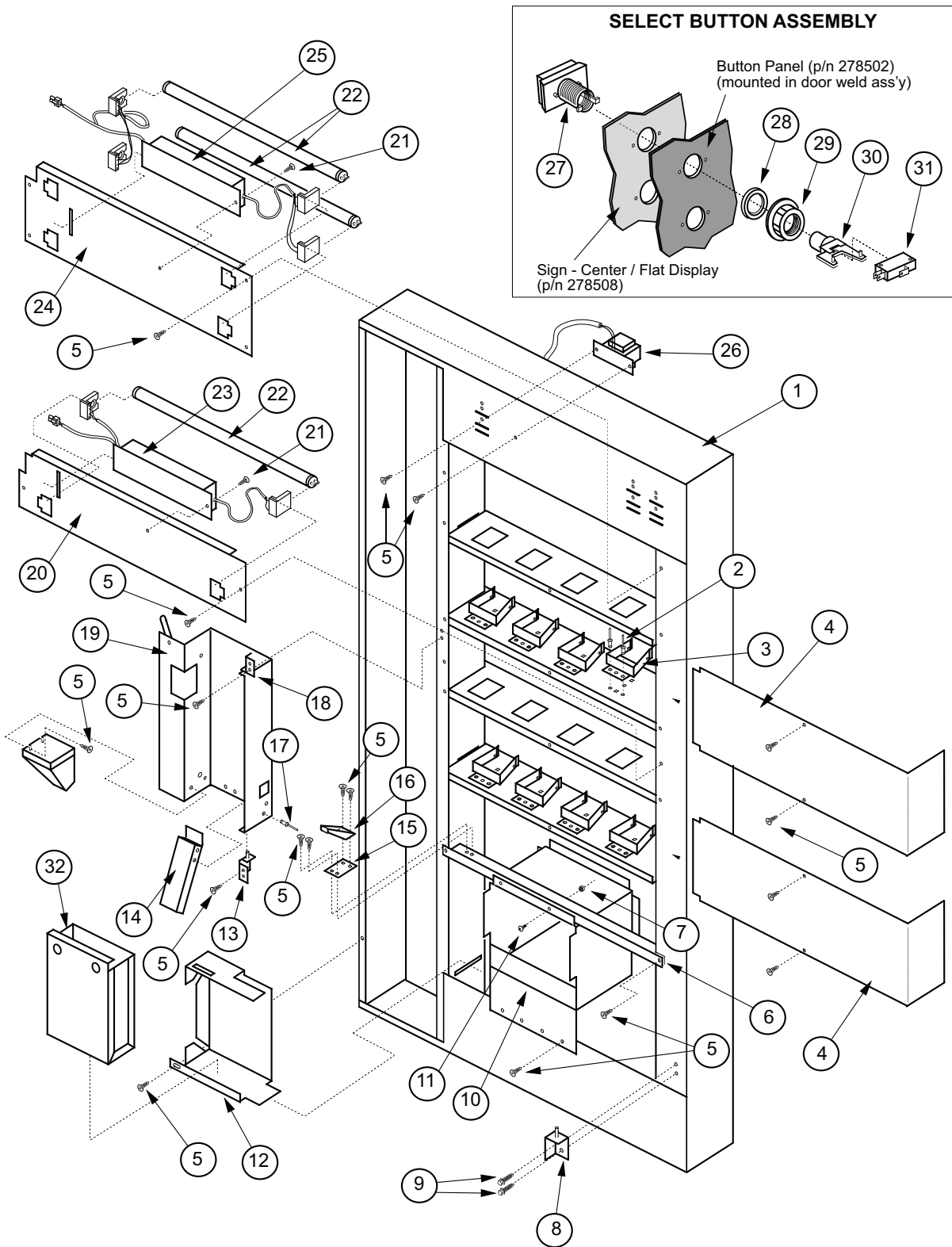

## Section 7. Exploded Views and Part Numbers

---

### Flat Horizontal Display, Door Rear

ITEM NUMBER	DESCRIPTION	PART NUMBER
1	Door Welded Assembly - Flat Display - 72" .....	278552
2	Pop Rivet 1/8" diameter .....	908004
3	Display Product Holder .....	023107
4	Display Back - Flat Display .....	278505
5	Screw #8 x 1/2" .....	902004
6	Port Brace, Wide Vender .....	010515
7	Nut 1/4-20 .....	905002
8	Inner Door Hinge, Bottom .....	010550
9	Self Tapping Screw 1/4-20 x 1" .....	901003
10	Port Body Welded Assembly - Flat Display .....	278520
11	Carriage Bolt 1/4-20 x 1/2" .....	901007
12	Coin Box Housing .....	010537
13	Bottom Changer Door Hinge W/A .....	010560
14	Bottom Coin Chute Assembly (to Coin Box) .....	012593
15	Latch Roller Bracket .....	010516
16	Burst Open Latch Strike .....	812003
17	Pop Rivet 1/8" dia. Stainless Steel .....	908001
18	Top Changer Door Hinge W/A .....	010570
19	Changer Door .....	010544
20	Lamp Panel - Bottom (Single Bulb) .....	278507
21	Screw #8-32 x 1/2" w Flat Washer .....	901006
22	Lamp 20 watt 24" long .....	841012
23	Ballast - Single Bulb .....	838005
	Ballast Assembly - Flat Display (Single Bulb) .....	122518
24	Lamp Panel - Top (Double Bulb) .....	278506
25	Ballast - Double Bulb .....	838024
	Ballast Assembly - Flat Display (Double Bulb) .....	122528
26	Transformer Assembly .....	842147
27	Button Assembly .....	not available
28	Washer, Select Button .....	not available
29	Nut, Select Button .....	not available
30	Switch Holder .....	not available
*	Complete Button Assembly (items 27, 28, 29, 30) .....	816016
31	Switch, Miniature .....	835001
32	Coin Box W/A .....	010580

# Section 7. Exploded Views and Part Numbers

## Flat Horizontal Display, Select Panel

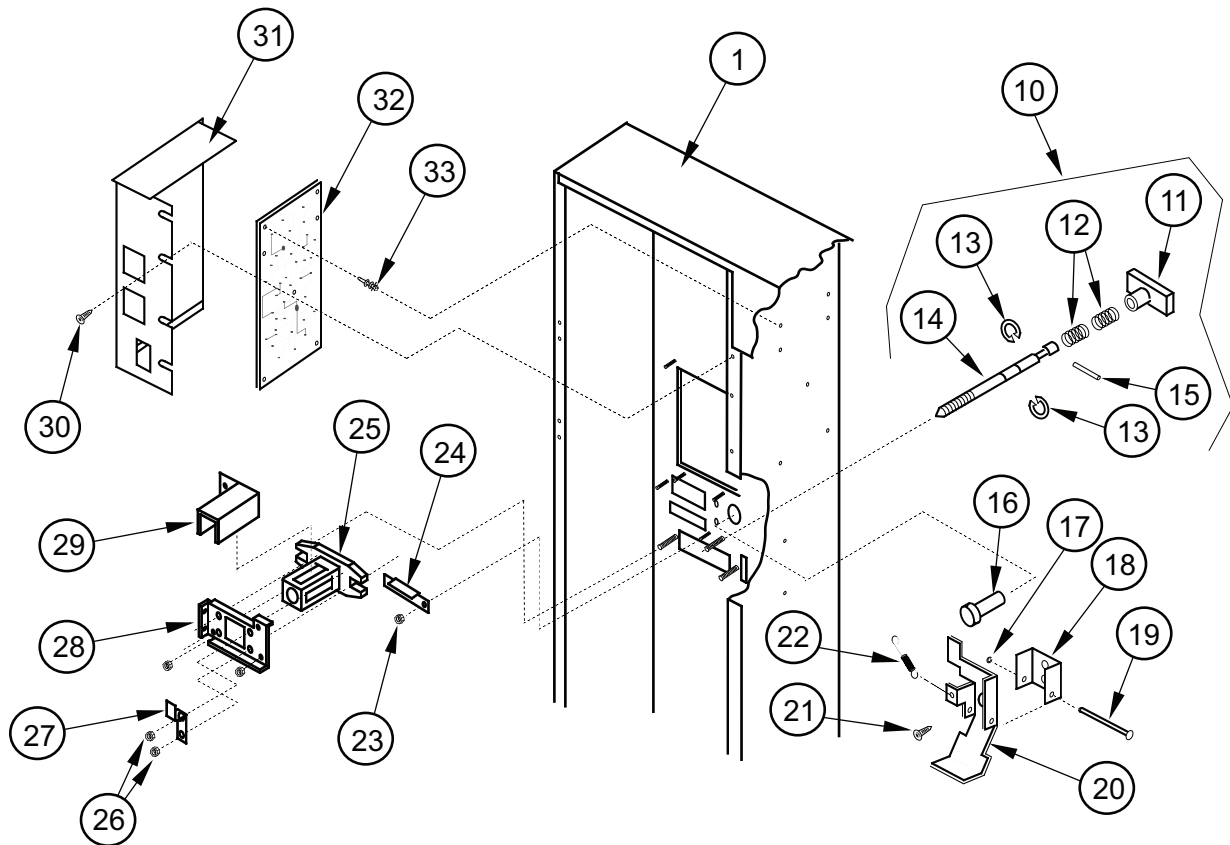
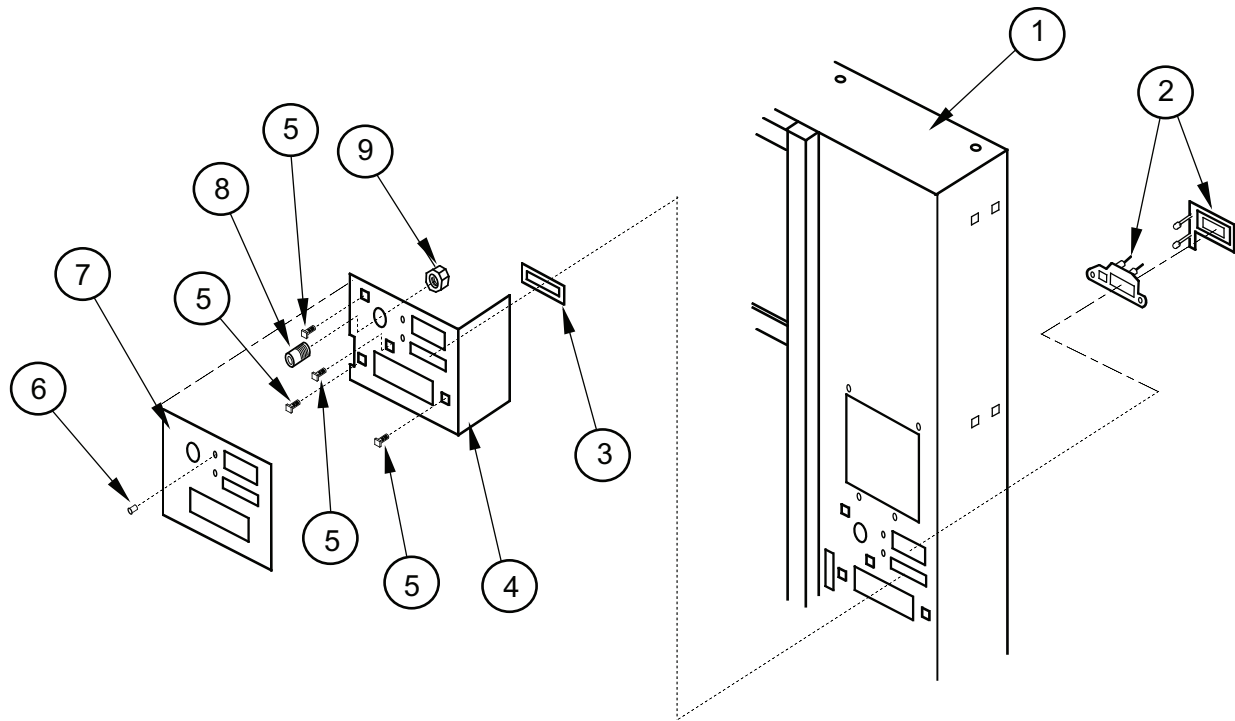

## Section 7. Exploded Views and Part Numbers

---

### Flat Horizontal Display, Select Panel

ITEM NUMBER	DESCRIPTION	PART NUMBER
1	Door Welded Assembly - Flat Display - 72" .....	278552
2	LED Display Assembly.....	010593
3	Coin Plate .....	141516
4	Security Plate Welded Assembly .....	216530
5	T-Screw 1/4-20 x 1" .....	901037
6	LED Lens (Part of LED Assembly).....	916032
7	Security Plate Decal .....	845641
8	Bushing (for coin return button) .....	803030
9	Hex Jam Nut 9/16-18.....	905019
10	T-Handle Assembly (prior to 1521) .....	812176
	-1521 and after .....	812289
11	T-Handle Body (part of T-Handle Assembly) .....	not available
12	Spring, T-Handle Assembly (part of T-Handle Assembly).....	not available
13	Retainer Ring, T-Handle (part of T-Handle Assembly).....	not available
14	T-Handle Stud (part of T-Handle Assembly) .....	not available
15	Pin, T-Handle (part of T-Handle Assembly) .....	not available
16	Button, Coin Return .....	803031
17	Retaining Ring 5/32" .....	906005
18	Hinge, Coin Return Lever .....	141506
19	Pin, Coin Return Lever .....	811002
20	Coin Return Lever.....	141504
21	Screw #8-32 x 3/8" .....	901011
22	Spring, Coin Return Lever .....	914003
23	Nut #8-32 .....	905001
24	Coin Ramp.....	141508
25	T-Handle Housing .....	812190
26	Nut 1/4-20 .....	905002
27	Lever Stop .....	141514
28	T-Handle Brace.....	141513
29	Lock Cylinder Cover .....	161532
30	Screw #8-18 x 1/2".....	902004
31	Control Board Cover .....	141903
32	Control Board.....	836134
33	PC Board Spacer.....	916027

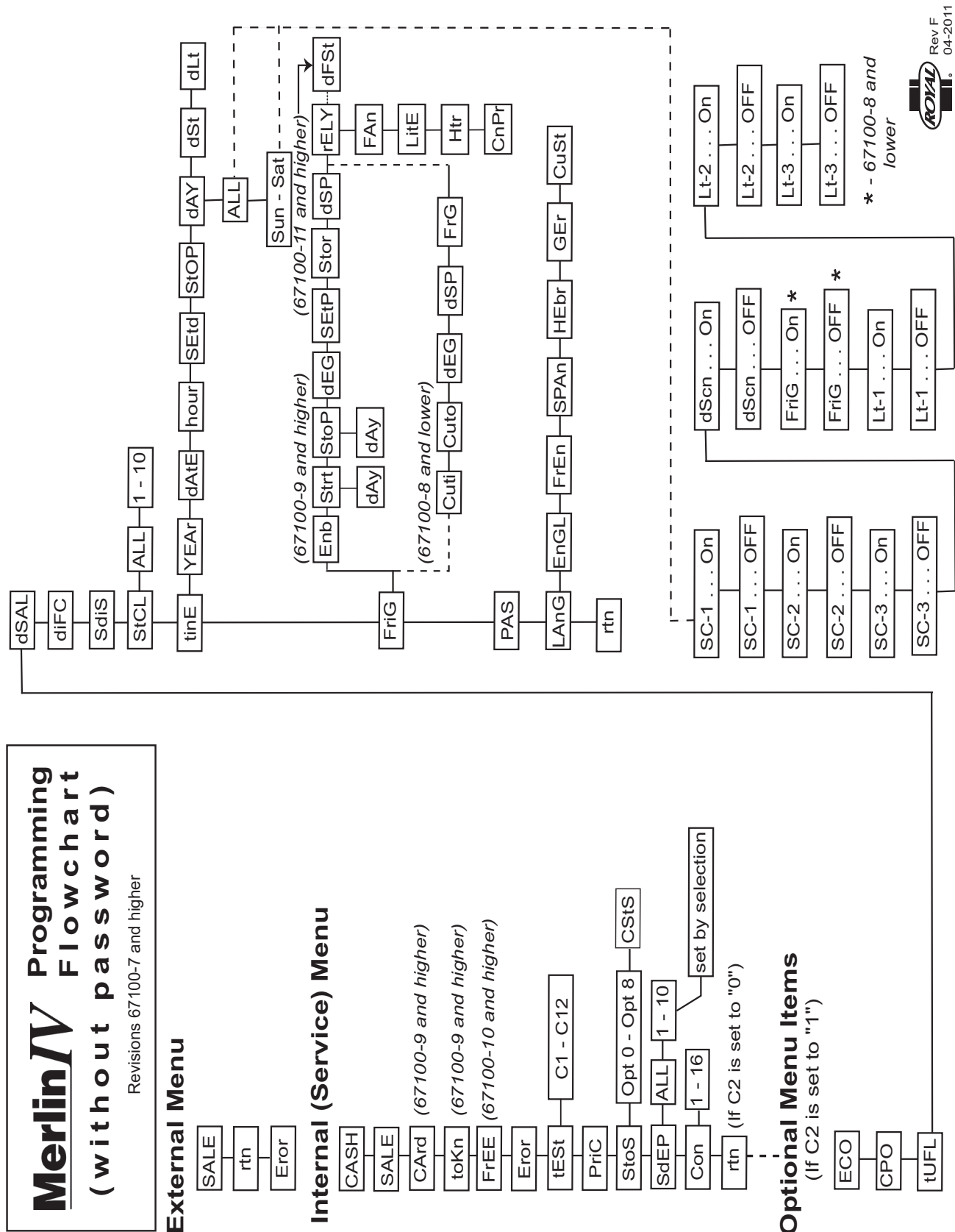

# Programming Flowcharts

## Merlin IV Programming Flowchart (password protected)

Prior to Revision 67100-7.  
Menu items preceded by an asterisk (\*) below will appear before "PASS" before Revision 67100-5.

### External Menu

Error  
SALE  
rtn

### Internal (Service) Menu

\* Error  
\* CPO  
\* tUFL  
\* tEST  
PASS  
rtn

### Password Protected Menu

CASH  
SALE  
dSAL  
dIFC  
PriC  
Sdis  
StoS  
Opt 0 - Opt 8  
CStS

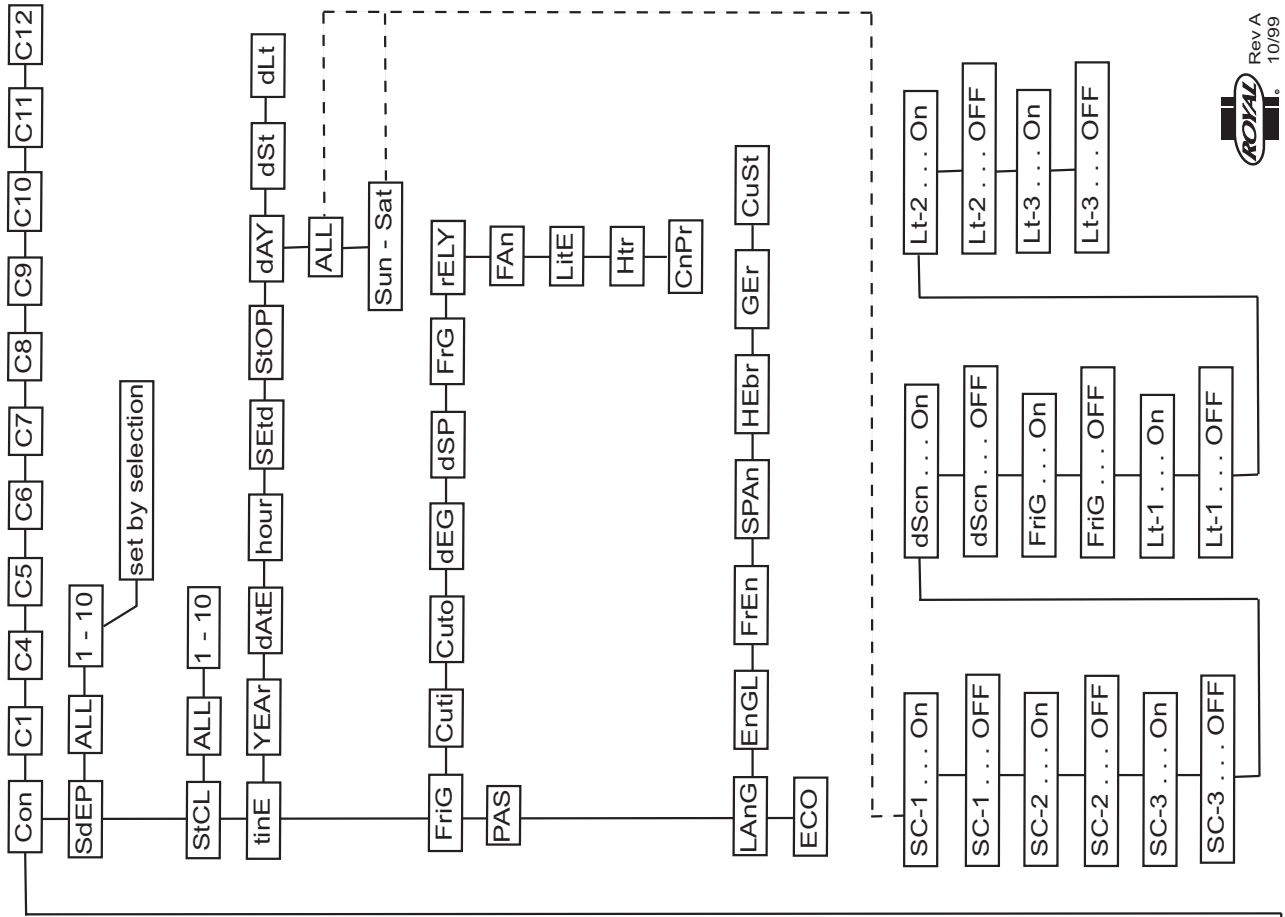







**Printed in the  
United States of America**

---

**Imprimé aux  
Etats-Unis d'Amérique**



Royal Vendors, Inc.

P/N **833021**  
Rev. **20** (January 2013)